

# CLIFF

## 1/4" S1V vertical PCB mounting Jack Sockets



S1V/SSB without chassis ground



S1VX/SBB with chassis ground

The **CLIFF**<sup>®</sup> range of S1V Jack Sockets incorporate significant new design features. The compact design offers the highest board packing density available. The design supports auto insertion and snap-in PCB mounting to facilitate assembly and wave soldering. The S1V is available with optional chassis grounding, a choice of either a plastic or metal nose, different fixing nut options and six circuit options.

### Significant features include:

- Compact vertical PCB mounting with 24mm stand-off gives high packing density.
- Snap-in PCB mounting to facilitate pre-assembly and wave soldering.
- Optional chassis grounding versions. Grounding chassis to plug and PCB.
- Body design supports auto-insertion.
- Compatible with most similar types.

**Cliff Electronic Components, Inc.**

4876 East Second Street,  
Benicia, California 94510

**Tel:** (707) 746 8090

**Fax:** (707) 746 8092

# CLIFF

## 1/4" S1V vertical PCB mounting Jack Sockets

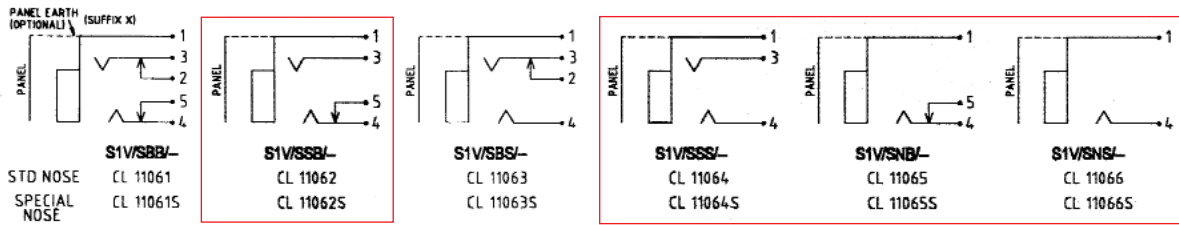
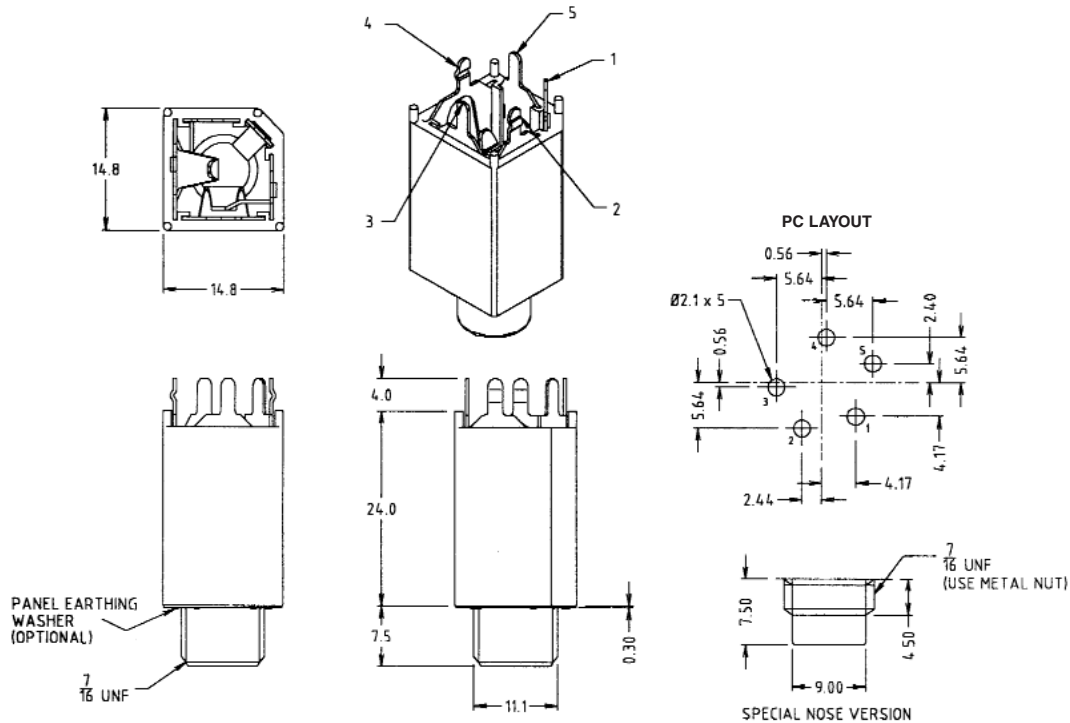

The versions shown in boxes are available as special order only.

**Technical Data:** Withstand voltage: 2000V DC Min.  
Maximum Current: 5 amp.  
Temperature Rating: -10° C to + 70° C  
Life (Minimum): 10,000+ Operations.  
Nominal Contact Resistance: <50mΩ

### Specifications:

Designed to receive both mono and stereo 1/4" jack plugs, the S1V socket is molded in durable grade 1 black nylon with **CLIFF**® Ni-Ag® Alloy self-cleaning contacts for superior performance and reliability. The S1V can be supplied with either a half threaded nose (specify 'SPN') or fully threaded nose and with a nylon nut (standard) or a nickel plated brass hexagonal or slotted ring nut. Mounting hardware, if required, is supplied unassembled. The S1V can also be supplied with prefitted EMI/RFI screen if required (add suffix 'X' to part no., for example S1VX / SBB).