

# TAP600 Series

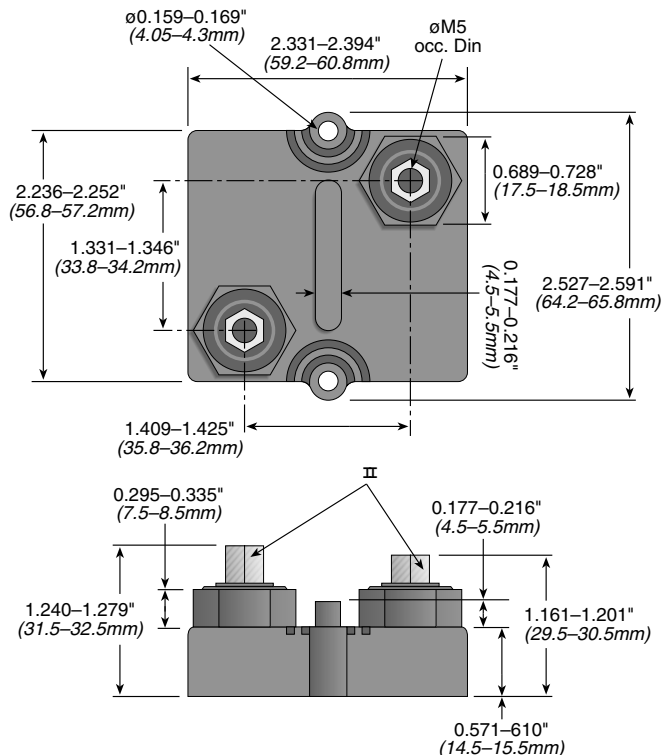

## 600 Watt Heat Sinkable Planar Resistors



### PERFORMANCE DATA

Test	Method	Typical Results - ΔR
Short Time Overload	1000 W/10 Sec. @ 70°C	0.4%
Humidity Steady State	56 Days/40°C/ 95°C	0.25%
Temp. Cycling	-55/+125/5 Cycles	0.20%
Shock	40g/4,000 Times	0.25%
Vibrations	2 - 500Hz/10g	0.25%
Load Life 1,000 Cycles	Pn 30 min. ON/30 min. OFF	0.40%
Terminal Strength of Contacts	200N	0.05%

### STOCK RESISTANCE VALUES

1.0	15	500
2.0	30	1000
3.0	50	2500
4.0	75	3000
5.0	100	5000
10	300	10,000

### DERATING CURVE

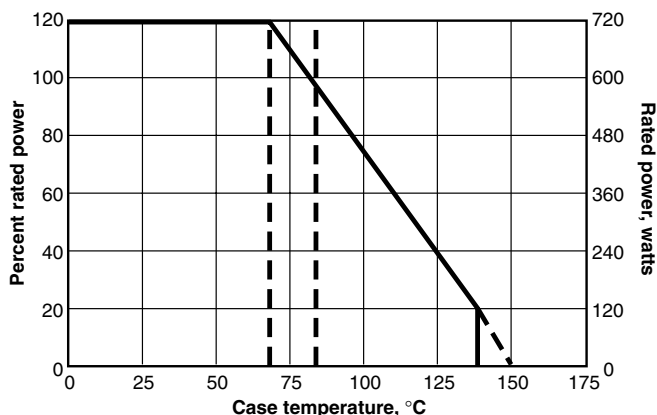

Ohmite's TAP600 delivers 600 watts of reliable power to a variety of power conditioning, power transmission, and power control applications. These resistors can be used designed for liquid, or air cooled heat sink systems used in variable speed drives, power supplies, robotics, motor control, and other control devices.

Resistance values range from 0.5Ω to 100KΩ in an easy to assemble package with a pre-calibrated mounting pressure to the cooling plate. The versatile TAP600 can be modified by request for dielectric strength up to 12KV, connector height up to 42mm, and terminal sleeves for insulation and creepage distances to 85mm. Contacts require the use of M5 screws.

### FEATURES

- Dielectric Strengths Up to 12KV
- Special Design for Low Inductive and Capacitance Values
- Easy Termination to Contacts with M5 Screws
- Calibrated Mounting Simplifies Assembly
- Designed to Customer Specifications

### SPECIFICATIONS

#### Electrical

Resistance Values: 0.5Ω to 100KΩ

**Resistance Tolerance:** ±10% Std., 5% available on request.

**Temperature Coefficient:** ±150ppm/°C (others upon request)

**Maximum Working Voltage:** 5,000V DC, higher voltage on request, not exceeding max. power

**Power Rating:** 600W at 70°C heat sink temperature

**Dielectric Strength Voltage:** 6k Vrms, 50Hz, 1min standard; up to 12k Vrms available

**Single Shot Voltage:** Up to 12KV Normwave (1.5/50 μsec)

**Insulation Resistance:** 10GΩ min. at 500V

**Creeping Distance:** 42mm min.

**Air Distance:** 14mm min.

**Inductance:** ≤80nH

**Capacitance/Mass:** ≤110pF

**Capacitance/Parallel:** ≤40pF

Operation Temperature: -55°C to +150°C

**Max. Torque for Contacts:** 2 Nm

**Max. Torque for Mounting:** 1.8 Nm

**Derating (thermal resist.):** 8.73W/°C (0.115°C/W)

**Power Rating:** 600W at 70°C heat sink temp.\*

\*This value is only valid by using a thermal conduction to the heat sink  
R<sub>th</sub> -cs<0.025°C/W.

The value can be reached by using thermal transfer compound with a heat conductivity of 1w/mk. The flatness of the cooling plate must be better than 0.05mm overall. The roughness of the surface should not exceed 6.4μm.

### ORDERING INFORMATION

E = RoHS compliant  
Available Jan. 2006

**TAP600K5R0E**

Style

Tolerance

J = 5%  
K = 10%, Std.  
L = 20%

Resistance

1 Ohm = 1R0  
10 Ohm = 10R  
1000 Ohm = 1K0

### PULSE FORMS

E-function, time between two pulses: 1 sec.

