



NABL

An ISO 9001 - 2000 Company ©

MFR



Electronic Components Pvt. Ltd.

www.mfrelectronics.com

ISO 9001 REGISTERED



DNV Certification B.V., The Netherlands

MGMT. SYS.
RvA C024

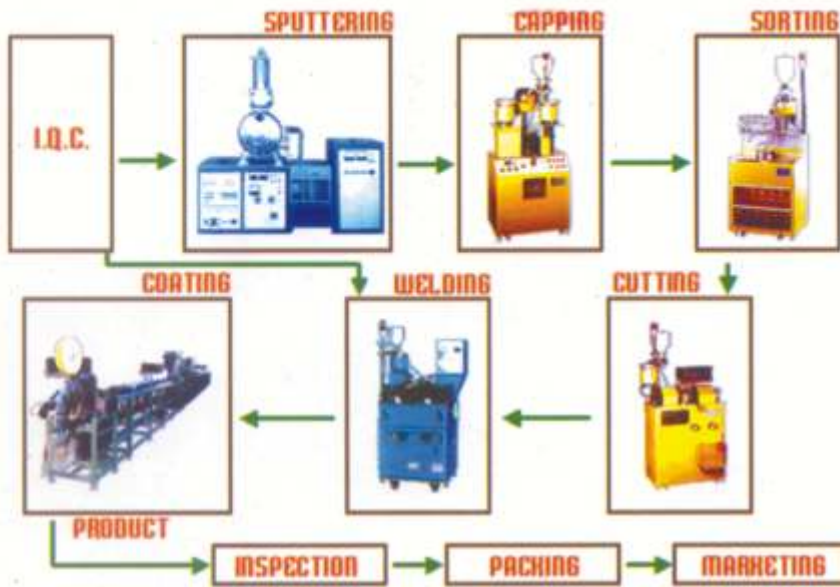

MFR Electronic Components (P) Ltd. is an ISO 9001 - 2000 Certified Company with over two decades of strong presence in the manufacture of wide range of resistor. At MFR we have adopted the "Planer Magnetron Sputtering" technology for depositing a thin, uniform resistive film of high consistency, stability and low temperature coefficient. Our exclusive mass production process is operated by competent trained personnel with stringent quality control, which result in high quality precision resistor.

The prestigious approval of the Defence, Aviation, Space, Telecommunication, and Railway Authorities established beyond any doubt the reliability and stability of our product. We are also a "Self-certified vendor" to multinationals due to our consistent supply of Zero-defect product

Being situated in "Special Economic Zone", MFR has an enviable global presence exporting to countries like USA, Mexico, Russia, Sweden, Singapore and Taiwan. With timely supplies at economical costs and on efficient service and distribution network, we constantly strive to deliver highly reliable and precise product.

To fulfill MFR's customers requirement of Screened Components MFR Electronics Test Lab was set up in 2003 and was accredited by NABL as per ISO17025-1999 STDs in Feb, 2004 presently approved by DGAQA & HAL Korwa

Factory and Regd. Office
 Unit No.40, SDF II, SEEPZ (SEZ),
 Andheri (East), Mumbai 400 096, India.
 Tel : 91 22 28291316 / 2829 0232
 28290353 Fax: 91 22 28290821.
 Email : mfr@vsnl.com

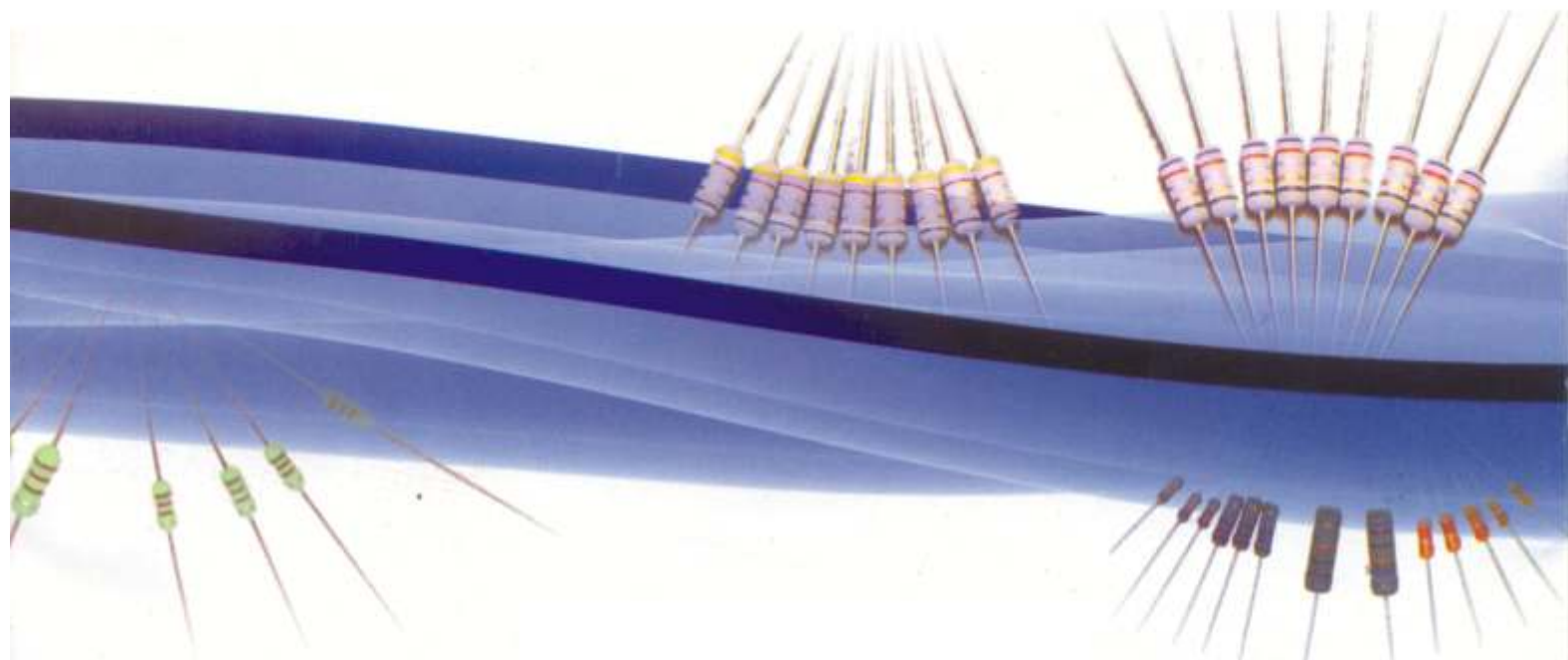

Distributors

Maharashtra : Precious Electronics Corporation Tel: 022 23860085 Fax: 022 23890540 Email: precious@vsnl.com
 Karnataka: Anugraha Agencies Tel: 080 23314699 Fax 080 23343371 Email: anugraha@blr.vsnl.net.in
 Tamil Nadu & Kerala : Anirudha Electronics Tel : 080 23494604 Fax: 080 23491212 Email: belco@vsnl.net
 Andhra Pradesh: Shilpa Electronics Tel 040 27849020 Fax 040 27849018 Email: shilpagp@satyam.net.in
 Dealership Enquiry Solicited

Approvals
LCSSO, CACT, C-DOT, RDSO,
VSSC, ISRO, AIR FORCE,
DGQA, DGAQA

METAL FILM RESISTORS

Series: MF / MFS

Construction:

Features:

- ▶ Meet performance requirements of JSS Std. & MIL Std.
- ▶ Flameproof Coating available on request.
- ▶ Miniature Size available for Space savings.
- ▶ TCR Available 25,50,100 ppm/° C.
- ▶ Available ranges from 10 Ohm ~ 1M Ohms.
- ▶ Value below above ranges available on request.

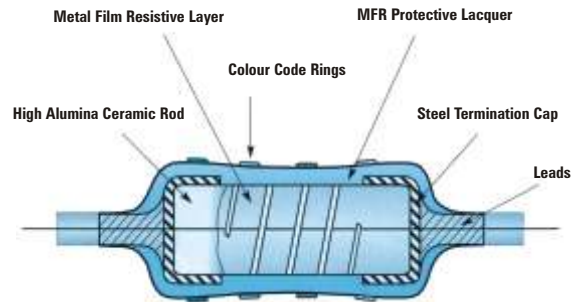

Dimension:

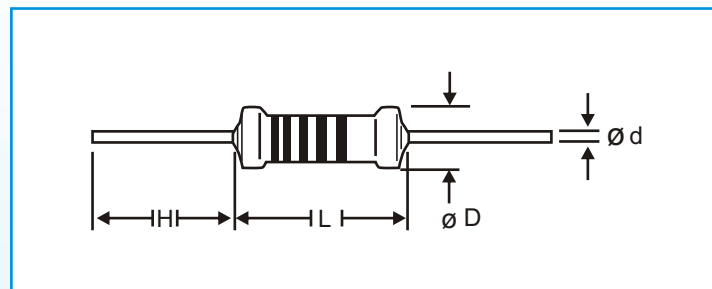

Physical Data :

| TYPE | POWER RATING | TOL (±) | DIMENSION (mm) | | | | Max. Working Voltage | Max.Overload Voltage |
|---------|--------------|----------|----------------|-----------|---------|-------------|----------------------|----------------------|
| | | | L | D | H (min) | d | | |
| MF 125 | 0.125W | 1%,2%,5% | 3.3 ± 0.5 | 1.7± 0.2 | 28 | 0.45 ± 0.05 | 200V | 400V |
| MFS 40 | 0.4W | 1% | 3.3 ± 0.5 | 1.7± 0.2 | 28 | 0.45 ± 0.05 | 200V | 400V |
| MF 25 | 0.25W | 1%,2%,5% | 6.5 ± 0.5 | 2.3± 0.2 | 25 | 0.60 ± 0.05 | 250V | 500V |
| MFS 60 | 0.6W | 1% | 6.5 ± 0.5 | 2.3± 0.2 | 25 | 0.60 ± 0.05 | 250V | 500V |
| MF 50 | 0.5W | 1%,2%,5% | 9.5 ± 1 | 3.5 ± 0.5 | 25 | 0.60 ± 0.05 | 350V | 700V |
| MFS 100 | 1W | 1%,5% | 9.5 ± 1 | 3.5 ± 0.5 | 25 | 0.60 ± 0.05 | 350V | 700V |
| MF 100 | 1W | 1%,5% | 12 ± 1 | 4.5 ± 0.5 | 25 | 0.80 ± 0.05 | 500V | 1000V |
| MFS 200 | 2W | 1%,5% | 12 ± 1 | 4.5 ± 0.5 | 25 | 0.80± 0.05 | 500V | 1000V |

Performance Data :

| TEST | PROCEDURE | SPEC. |
|---------------------------------|--|--|
| Dielectric Withstanding Voltage | V- Block Method, 3X Rated Voltage Duration : 1 Min. | $\Delta R = (0.25\% + 0.05 \text{ Ohm})$ |
| Insulation Resistance | V- Block Method, DC 500V Duration : 1 Min. | $> 10,000 \text{ M Ohm}$ |
| Temp. Cycling | 5 cycles of - 65° C, 25° C, +155° C, 25° C | $\Delta R = (1\% + 0.05 \text{ Ohm})$ |
| Short Time Overload | 2.5 X Rated Voltage Duration : 5 sec. | $\Delta R = (0.25\% + 0.05 \text{ Ohm})$ |
| Damp Heat Steady State | 40°C 95% relative humidity, Duration : 56 Days. | $\Delta R = (1\% + 0.05 \text{ Ohm})$ |
| Load Life | Rated Voltage at 70°C ambient Duration : 2000 Hrs. | $\Delta R = (1\% + 0.05 \text{ Ohm})$ |
| Robustness of Terminations | Tensile :10N Duration: 10 Sec. Bending :180°, > 3 Bends Torsion :3 Rotation of 360° Each | $\Delta R = (0.25\% + 0.05 \text{ Ohm})$ |
| Resistance to Soldering Heat | Temp. 260° C \pm 5° C Duration :10 Sec. | $\Delta R = (0.25\% + 0.05 \text{ Ohm})$ |
| Shock (Medium Impact) | 1 Km/S ² | $\Delta R = (0.25\% + 0.05 \text{ Ohm})$ |
| Vibration (High Frequency) | 10 to 2000 Hz : m/S ² | $\Delta R = (0.25\% + 0.05 \text{ Ohm})$ |
| Low Temp. Exposure | At -65° C Duration :2 Hrs. | $\Delta R = (0.25\% + 0.05 \text{ Ohm})$ |
| High Temp. Exposure | At +155° C Duration :16 Hrs.No Load Condition | $\Delta R = (1\% + 0.05 \text{ Ohm})$ |
| Solderability | Dip Method, Solder Bath Temp. 230° C \pm 5° C. Duration 5 Sec. | 95% Coverage |
| Resistance to Solvent | Solvent : Trichloroethylene Duration :3 Min. | Marking should be legible |

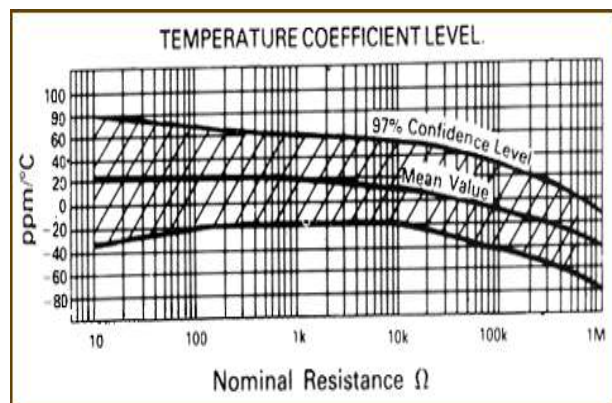
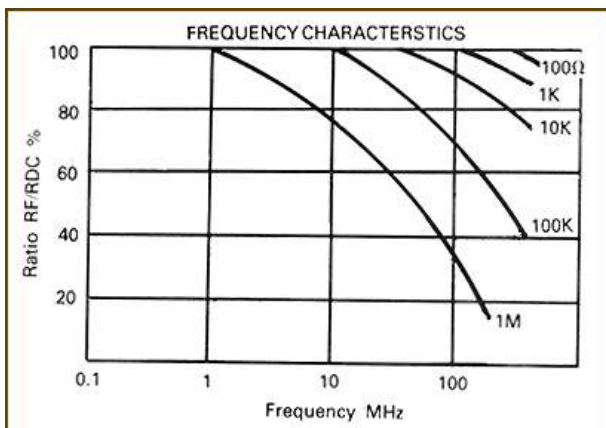
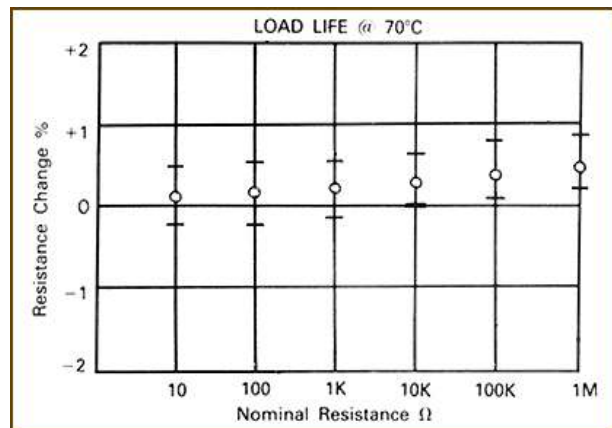
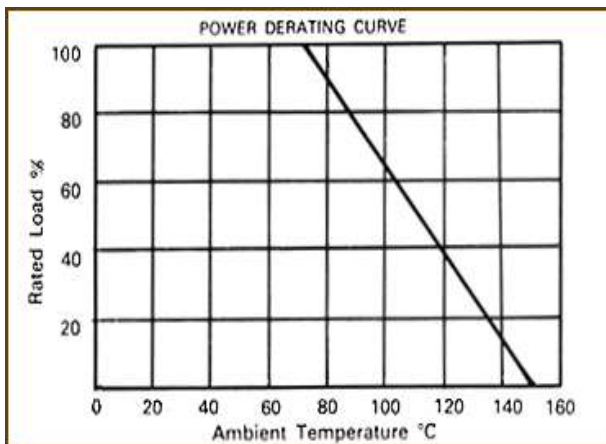

PRECISION METAL FILM RESISTORS

Series: MF P / MFS P

Construction:

Features:

- ▶ Meet performance requirements of JSS Std. & MIL Std.
- ▶ Close Tolerance available 0.01% ~ 0.5 %.
- ▶ Flameproof Coating available on request.
- ▶ Miniature Size available for Space savings.
- ▶ TCR available 5, 10, 15, 25, 50 ppm/° C.
- ▶ Available ranges from 10 Ohm ~ 1M Ohms.
- ▶ Lower Tolerances available on request.

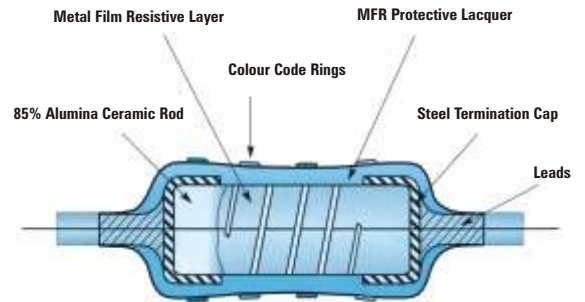

Dimensions

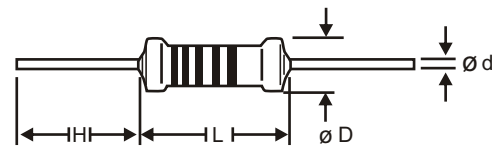

Physical Data :

| TYPE | POWER RATING | TOL (±) | DIMENSION (mm) | | | | Max. Working Voltage | Max. Overload Voltage |
|----------|--------------|---------------------------|----------------|-----------|---------|-------------|----------------------|-----------------------|
| | | | L | D | H (min) | d | | |
| MF 125P | 0.125W | 0.1% | 3.3±0.5 | 1.7±0.2 | 28 | 0.45 ± 0.05 | 200V | 400V |
| MFS 40P | 0.125W | 0.1% | 3.3±0.5 | 1.7±0.2 | 28 | 0.45 ± 0.05 | 200V | 400V |
| | 0.4W | | | | | | | |
| MF 25P | 0.25W | 0.02%, 0.1%, 0.25%, 0.5% | 6.3±0.5 | 2.3±0.2 | 25 | 0.60 ± 0.05 | 250V | 500V |
| MFS 60P | 0.25W | 0.02%, 0.1%, 0.25%, 0.5% | 6.3±0.5 | 2.3±0.2 | 25 | 0.60 ± 0.05 | 250V | 500V |
| | 0.6W | | | | | | | |
| MF 50P | 0.5W | 0.025%, 0.1%, 0.25%, 0.5% | 9.5±1 | 3.5 ± 0.5 | 25 | 0.60 ± 0.05 | 350V | 700V |
| MFS 100P | 0.5W | 0.1%, 0.25%, 0.5% | 9.5±1 | 3.5 ± 0.5 | 25 | 0.60 ± 0.05 | 350V | 700V |
| | 1W | | | | | | | |
| MF 100P | 2W | 0.1%, 0.25%, 0.5% | 12±1 | 5.5 ± 0.5 | 25 | 0.80± 0.05 | 500V | 1000V |
| MFS 200P | 1W | 0.1%, 0.25%, 0.5% | 12±1 | 4.5 ± 0.5 | 25 | 0.80± 0.05 | 500V | 1000V |
| | 2W | | | | | | | |
| MF 200P | 2W | 0.1%, 0.25%, 0.5% | 16±1 | 5.5 ± 0.5 | 32 | 0.80± 0.05 | 500V | 1000V |
| MFS 300P | 2W | 0.1%, 0.25%, 0.5% | 16±1 | 5.5 ± 0.5 | 32 | 0.80± 0.05 | 500V | 1000V |
| | 3W | | | | | | | |

Derating Curve

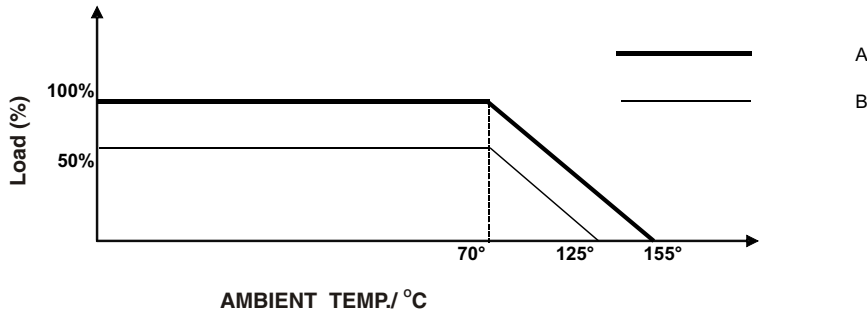

Performance Data :

| A | B |
|-----------------------|-----------------|
| MF 25P, MFS40 (0.4W) | MFS40P (0.125W) |
| MF 25P, MFS60P (0.6W) | MFS60P (0.25W) |
| MF 50P, MFS100P (1W) | MFS100 P(0.50W) |
| MF 100P, MF200P (2W) | MFS200P(1W) |
| MF 200P, MFS300P | |

| TEST | PROCEDURE | SPEC. | ACTUAL PERFORMANCE | | | |
|---------------------------------|--|---|----------------------|----------------------|----------------------|----------------------|
| | | | MAX. | TYPICAL | MAX. | TYPICAL |
| Dielectric Withstanding Voltage | V-Block Method, 3X Rated Voltage Duration : 1 Min. | $\Delta R = (0.2\% + 0.1 \text{ Ohm})$ | 0.06% | 0.02% | 0.05% | 0.01% |
| Insulation Resistance | V-Block Method, DC 500V Duration : 1 Min. | 10, 000 M Ohm | | | | |
| Temp. Cycling | 5 cycles of - 65°C, 25°C, +155°C, 25°C | $\Delta R = (0.2\% + 0.02 \text{ Ohm})$ | 0.15% | 0.05% | 0.05% | 0.03% |
| Short Time Overload | 2.5X Rated Voltage Duration : 5 sec. | $\Delta R = (0.2\% + 0.01 \text{ Ohm})$ | 0.1% | 0.02% | 0.05% | 0.02% |
| Damp Heat Steady State | 40°C95% relative humidity, Duration : 56 Day. | $\Delta R = (0.5\% + 0.01 \text{ Ohm})$ | 0.3% | 0.1% | 0.05% | 0.03% |
| Load Life | Rated Voltage at 70°C ambient Duration : 2000 Hrs. | $\Delta R = (0.5\% + 0.01 \text{ Ohm})$ | 0.3% | 0.1% | 0.1% | 0.05% |
| Robustness of Terminations | Tensile: 10N Duration: 10 Sec. Bending : 180°, > 3 Bends Torsion : 3 Rotation of 360° Each | $\Delta R = (0.2\% + 0.01 \text{ Ohm})$ | 0.06% | 0.02% | 0.03% | 0.01% |
| Resistance to Soldering Heat | Temp. 260°C \pm 5°C Duration : 10 Sec. | $\Delta R = (0.1\% + 0.01 \text{ Ohm})$ | 0.06% | 0.03% | 0.03% | 0.01% |
| Shock (Medium Impact) | 1 Km/S ² | $\Delta R = (0.2\% + 0.01 \text{ Ohm})$ | 0.06% | 0.02% | 0.05% | 0.01% |
| Vibration (High Frequency) | 10 to 2000 Hz: m/S ² | $\Delta R = (0.2\% + 0.01 \text{ Ohm})$ | 0.06% | 0.02% | 0.05% | 0.01% |
| Low Temp. Exposure | At - 65°C Duration : 2 Hrs. | $\Delta R = (0.2\% + 0.01 \text{ Ohm})$ | 0.15% | 0.05% | 0.05% | 0.03% |
| High Temp. Exposure | At +155°C Duration : 16 Hrs. No Load Condition | $\Delta R = (0.5\% + 0.01 \text{ Ohm})$ | 0.3% | 0.1% | 0.05% | 0.03% |
| Solderability | Dip Method, Solder Bath Temp. 230°C \pm 5 °C. Duration 5 Sec. | 95% Coverage | 95% Coverage | 95% Coverage | 95% Coverage | 95% Coverage |
| Resistance to Solvent | Solvent : Trichloroethylene Duration : 3 Min. | Marking should be legible | No effect on Marking | No effect on Marking | No effect on Marking | No effect on Marking |

MOULDED RESISTORS

Series: RNC

Derating Curve

Features:

- ▶ High grade alumina core.
- ▶ Encapsulated with compression moulded
- ▶ Phenolic plastic material.
- ▶ Flame resistant.
- ▶ Resistance range 10E~1M.
- ▶ TCR's : 10, 15, 25, 50, 100 ppm/°C.
- ▶ Tolerance 0.02% ~ 1%

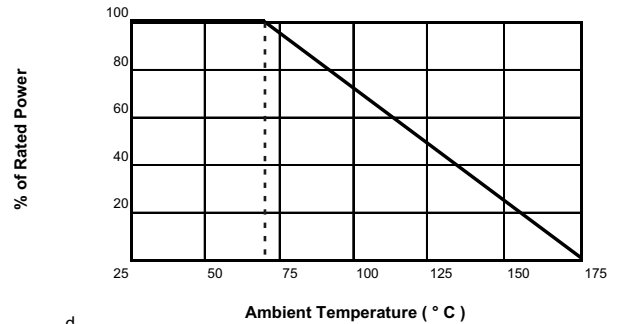

Dimensions:

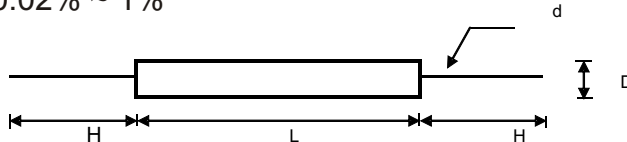

Physical Data :

| TYPE | RATED POWER 70° C | DIMENSION (mm) | | | | Max. Working Voltage |
|--------|----------------------|----------------|------------|---------|-------------|----------------------|
| | | L | D | H (min) | d | |
| RNC 55 | 0.125W | 6.35 ± 0.8 | 2.39 ± 0.8 | 30 | 0.60 ± 0.05 | 200V |
| RNC 60 | 0.25W | 9.5 ± 1.5 | 3.18 ± 0.9 | 30 | 0.60 ± 0.05 | 250V |

Performance Data :

| TEST | PROCEDURE | SPEC. |
|---------------------------------|---|---|
| Dielectric Withstanding Voltage | V-Block Method, 3X Rated Voltage Duration : 1 Min. | $\Delta R < \pm (0.5\% + 0.01 \text{ Ohm})$ No Breakdown |
| Insulation Resistance | V-Block Method, DC 500V Duration : 1 Min. | 10, 000 M Ohm |
| Temp. Cycling | 5 cycles of - 65°C, 25°C, +155°C, 25°C | $\Delta R < \pm (0.2\% + 0.01 \text{ Ohm})$ |
| Short Time Overload | 2.5X Rated Voltage Duration : 5 sec. | $\Delta R < \pm (0.2\% + 0.01 \text{ Ohm})$ |
| Damp Heat Steady State | 40°C/95% relative humidity, Duration : 56 Day. | $\Delta R < \pm (0.4\% + 0.01 \text{ Ohm})$ |
| Load Life | Rated Voltage at 70°C ambient Duration : 2000 Hrs. | $\Delta R < \pm (0.5\% + 0.01 \text{ Ohm})$ |
| Robustness of Terminations | Tensile : 10N Duration: 10 Sec. Bending : 180°, > 3 Bends Torsion : 3 Rotation of 360° Each | $\Delta R < \pm (0.2\% + 0.01 \text{ Ohm})$ No Mechanical Damage |
| Resistance to Soldering Heat | Temp. 260°C ± 5°C Duration : 10 Sec. | $\Delta R < \pm (0.1\% + 0.01 \text{ Ohm})$ |
| Shock (Medium Impact) | 1 Km/S ² | $\Delta R < \pm (0.2\% + 0.01 \text{ Ohm})$ |
| Vibration (High Frequency) | 10 to 2000 Hz: m/S ² | $\Delta R < \pm (0.2\% + 0.01 \text{ Ohm})$ |
| Low Temp. Exposure | At - 65°C Duration : 2 Hrs. | $\Delta R < \pm (0.15\% + 0.01 \text{ Ohm})$ |
| High Temp. Exposure | At +155°C Duration : 16 Hrs. No Load Condition | $\Delta R < \pm (2\% + 0.05 \text{ Ohm})$ |
| Solderability | Dip Method, Solder Bath Temp. 230°C ± 5 °C. Duration 5 Sec. | > 95% Coverage |
| Resistance to Solvent | Solvent : Trichloroethylene Duration : 3 Min. | Marking should be legible |

High Precision and Stability Moulded Radial Resistors

Series: MRR

Features:

- ▶ Very high tolerance $\pm 0.01\%$ to $\pm 1\%$
- ▶ Very low temperature co-efficient
- ▶ Electrical insulation $> 10^6 M\Omega$
- ▶ Very High Stability

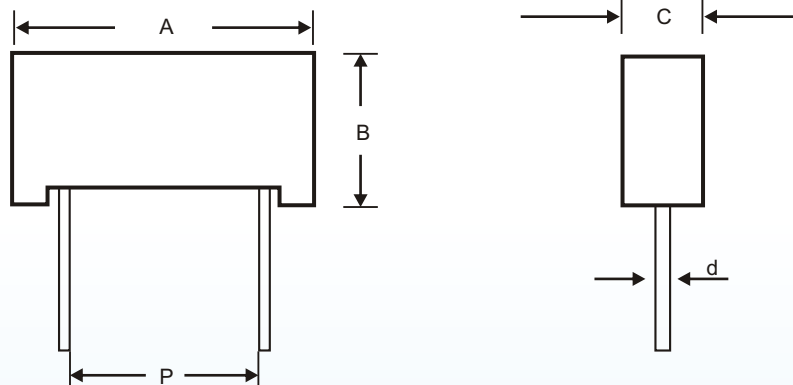

Dimension :

| WATTAGE | A | B | C | P | d |
|---------|-------------------|---------------------|------------------|-------------------|---------------------|
| 0.5W | 14 \pm 0.5 (mm) | 10.5 \pm 0.5 (mm) | 5 \pm 0.3 (mm) | 10 \pm 0.5 (mm) | 0.60 \pm 0.05(mm) |
| 1W | 14 \pm 0.5 (mm) | 10.5 \pm 0.5 (mm) | 5 \pm 0.3 (mm) | 10 \pm 0.5 (mm) | 0.60 \pm 0.05(mm) |

Performance Data

| TEST | CONDITION | REQUIREMENTS | TYPICAL |
|------------------------------|--|--------------|---------------|
| Short Time Overload | 2.5 x Rated Voltage Duration : 5 sec. | $\pm 0.2\%$ | $\pm 0.05\%$ |
| Load Life | Rated Voltage at 70°C ambient Duration : 2000 Hrs. | $\pm 0.5\%$ | $\pm 0.2\%$ |
| Robustness of Terminations | Tensile : 10N Duration 10 Sec. Bending : 180°, > 3 Bends Torsion : 3 Rotation of 360° Each | $\pm 0.2\%$ | $\pm 0.05\%$ |
| Resistance to Soldering Heat | Temp. 260°C \pm 5°C Duration : 10 Sec. | $\pm 0.1\%$ | $\pm 0.05\%$ |
| Vibration (High Frequency) | 10 to 2000 Hz : m/S ² | $\pm 0.2\%$ | $\pm 0.05\%$ |
| High Temp. Exposure | At +155°C Duration : 16 Hrs. No Load Condition | $\pm 0.5\%$ | $\pm 0.1\%$ |
| Temperature cycling | At -55°C At +155°C | $\pm 0.2\%$ | $\pm 0.025\%$ |

Electrical Specification :

| | |
|-----------------------|---------------------|
| Qualified Ohmic Range | 80R6 to 120K |
| Insulation Resistance | > 10 ⁶ M |

Power Rating

In order to increase stability, it is recommended to reduce the nominal power (Pr) in relation with tolerance.

For $\pm 0.1\%$ to $\pm 0.05\%$ Power = Pr x 0.75

For $\pm 0.02\%$ to $\pm 0.01\%$ Power = Pr x 0.5

Noise

< 0.025 microV/V RMS (> - 32dB)

Derating Curve

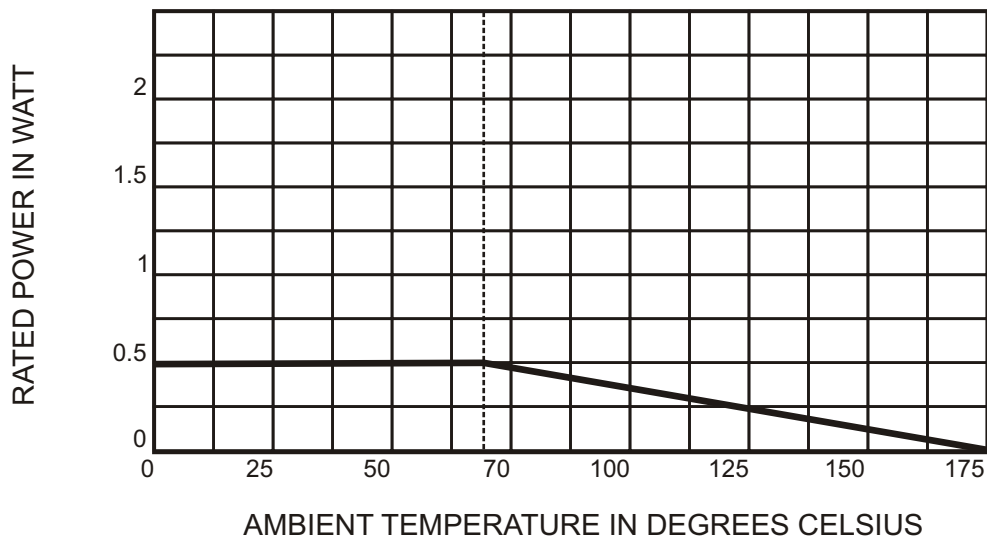

METAL OXIDE RESISTORS

Series: MO / MOS

Construction:

Features:

- ▶ Small in Size.
- ▶ Electrical & mechanical stability & high reliability.
- ▶ Best resistive to heat, humidity and noncombustible.
- ▶ Low noise, with high resistance value which Wire Wound type can not be produced.
- ▶ Available ranges from 10 Ohm ~ 1M Ohms.
- ▶ TCR Available 200 , 350 ppm/° C.
- ▶ Miniature Size available for Space savings.

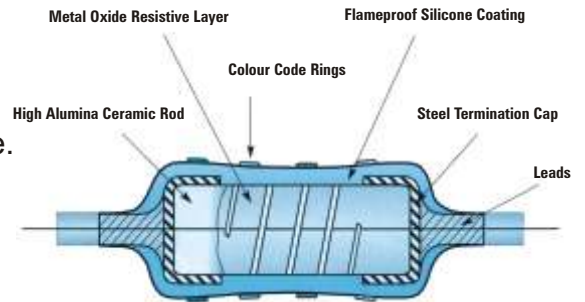

Dimensions:

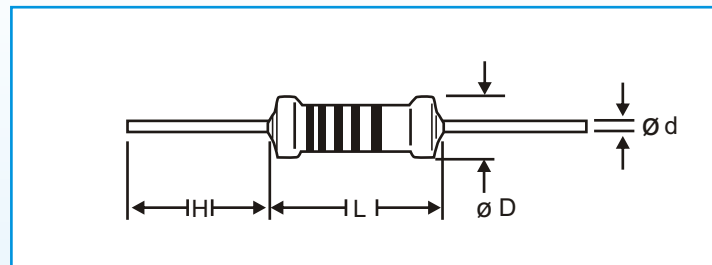

Physical Data :

| TYPE | POWER RATING | TOL (±) | DIMENSION mm | | | | Max. Working Voltage | Max.Overload Voltage |
|---------|--------------|---------|--------------|-----------|---------|------------|----------------------|----------------------|
| | | | L | D | H (min) | d | | |
| MO 25 | 0.25W | 5% | 6.5 ± 0.5 | 2.3 ± 0.2 | 28 | 0.6 ± 0.05 | 250V | 500V |
| MOS 50 | 0.5W | 5% | 6.5 ± 0.5 | 2.3 ± 0.2 | 28 | 0.6 ± 0.05 | 250V | 500V |
| MO 50 | 0.5W | 5% | 9.5 ± 1 | 3.5 ± 0.5 | 25 | 0.6 ± 0.05 | 350V | 700V |
| MOS 100 | 1W | 5% | 9.5 ± 1 | 3.5 ± 0.5 | 25 | 0.6 ± 0.05 | 350V | 700V |
| MO100 | 1W | 5% | 12 ± 1 | 4.5 ± 0.5 | 25 | 0.8 ± 0.05 | 500V | 1000V |
| MOS 200 | 2W | 5% | 12 ± 1 | 4.5 ± 0.5 | 25 | 0.8 ± 0.05 | 500V | 1000V |
| MO 200 | 2W | 5% | 16 ± 1 | 5.5 ± 0.5 | 32 | 0.8 ± 0.05 | 500V | 1000V |
| MOS 300 | 3W | 5% | 16 ± 1 | 5.5 ± 0.5 | 32 | 0.8 ± 0.05 | 500V | 1000V |

Performance Data :

| TEST | PROCEDURE | SPEC. |
|---------------------------------|--|--|
| Dielectric Withstanding Voltage | V- Block Method, 3X Rated Voltage Duration : 1 Min. | $\Delta R = (0.5\% + 0.05 \text{ Ohm })$ |
| Insulation Resistance | V- Block Method, DC 500V Duration : 1 Min. | >10,000 M Ohm |
| Temp. Cycling | 5 cycles of - 65° C, 25° C, +155° C, 25° C | $\Delta R = (1\% + 0.05 \text{ Ohm })$ |
| Short Time Overload | 2.5 X Rated Voltage Duration : 5 sec. | $\Delta R = (1\% + 0.05 \text{ Ohm })$ |
| Damp Heat Steady State | 40°C 95% relative humidity, Duration : 56 Days. | $\Delta R = (5\% + 0.05 \text{ Ohm })$ |
| Load Life | Rated Voltage at 70°C ambient Duration : 2000 Hrs. | $\Delta R = (5\% + 0.05 \text{ Ohm })$ |
| Robustness of Terminations | Tensile :10N Duration: 10 Sec. Bending :180°, > 3 Bends Torsion :3 Rotation of 360° Each | $\Delta R = (0.5\% + 0.05 \text{ Ohm })$ |
| Resistance to Soldering Heat | Temp. 260° C \pm 5° C Duration :10 Sec. | $\Delta R = (1\% + 0.05 \text{ Ohm })$ |
| Shock (Medium Impact) | 1 Km/S ² | $\Delta R = (1\% + 0.05 \text{ Ohm })$ |
| Vibration (High Frequency) | 10 to 2000 Hz : m/S ² | $\Delta R = (1\% + 0.05 \text{ Ohm })$ |
| Low Temp. Exposure | At -65° C Duration :2 Hrs. | $\Delta R = (1\% + 0.05 \text{ Ohm })$ |
| High Temp. Exposure | At +155° C Duration :16 Hrs.No Load Condition | $\Delta R = (5\% + 0.05 \text{ Ohm })$ |
| Solderability | Dip Method, Solder Bath Temp. 230° C \pm 5° C. Duration 5 Sec. | 95% Coverage |
| Resistance to Solvent | Solvent : Trichloroethylene Duration : 3 Min. | Marking should be legible |

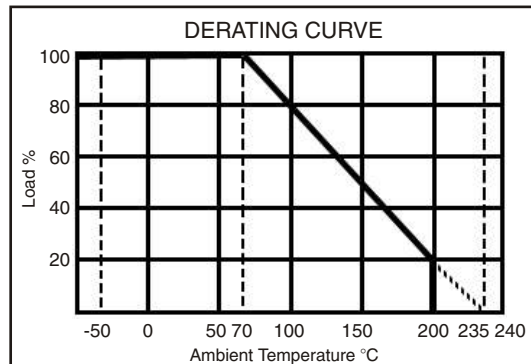

SURFACE TEMP. RISE

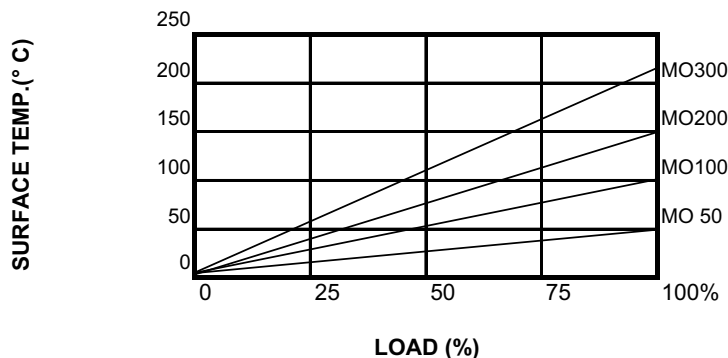

POWER METAL FILM RESISTORS

Series: MPR01, MPR02, MPR03

Construction:

Features:

- ▶ High Power in small packages.
- ▶ Lead (Pb)-free solder contacts.
- ▶ Pure tin plating provides compatibility with lead (Pb)-free and lead containing soldering processes.

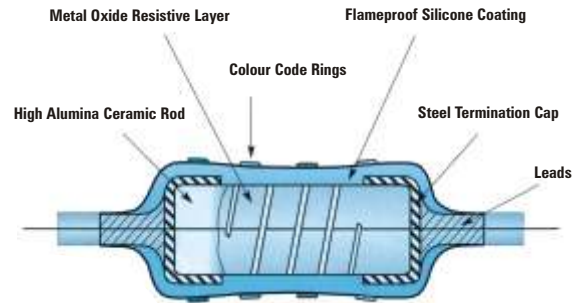

Applications :

- ▶ All general purpose power applications

Technical Specifications :

| Description | MPR01 | MPR02 | MPR03 |
|--|--|-----------------------|-----------------------|
| | | Cu-lead | |
| Resistance range | 0.22 Ohm ~ 1 M Ohm | 0.33 Ohm ~ 1 M Ohm | 0.68 Ohm ~ 1 M Ohm |
| Resistance tolerance and series | ± 1% (E-24, E-96 Series); ± 5% (E-24 Series) | | |
| Maximum dissipation at $T_{amb} = 70^{\circ}C$ | | | |
| R < 1 Ohm | 0.6 W | 1.2 W | 2 W |
| 1 Ohm ≤ R | 1 W | 2 W | 3 W |
| Thermal Resistance (R_{th}) | 75 K/W | | |
| Temperature Co-efficient | ≤ ± 250 ppm/°C | | |
| Maximum Permissible Voltage | 350 V | 500 V | 750 V |
| Basic Specification | IEC 60115 - 1 and 60115 - 4 | | |
| Climatic Category | 55/155/56 | | |
| Stability after : | | | |
| Load | Δ R/R max.: ±5% + 0.1 Ohm | | |
| Climatic tests | Δ R/R max.: ±3% + 0.1 Ohm | | |
| Soldering | Δ R/R max.: ±1% + 0.05 Ohm | | |

Dimensions :

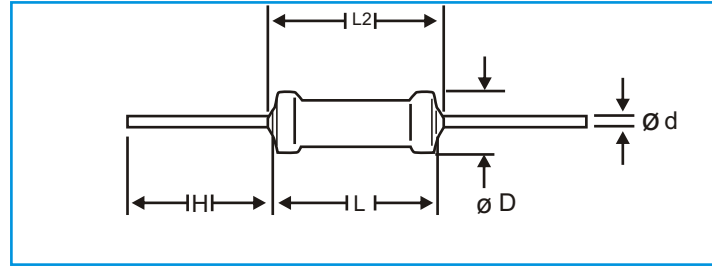

| TYPE | øD MAX (mm) | L MAX. (mm) | L2 MAX. (mm) | H MIN. (mm) | ød (mm) |
|-------|-------------------|-------------------|--------------------|-------------------|-------------|
| | | | | | cu |
| MPR01 | 2.5 | 6.5 | 8.5 | 25 | 0.58 ± 0.05 |
| MPR02 | 3.9 | 10.0 | 12.0 | 25 | 0.78 ± 0.05 |
| MPR03 | 5.2 | 15 | 17 | 28 | 0.78 ± 0.05 |

Mass Per 100 Units

| TYPE | MASS (g) |
|-----------------|----------|
| MPR01 Cu 0.6 mm | 21.2 |
| MPR02 Cu 0.8 mm | 50.4 |
| MPR03 Cu 0.8 mm | 119.2 |

Performance Data

| TYPE | PROCEDURE | SPEC. |
|---------------------------|--|-------------------------------|
| Insulation Resistance | Max voltage (DC) after 1 min V block method | 10,000 M Ohms |
| Robustness of Termination | load 10 N, 10s load 5 N, 4x90° 3x360° in opposite directions | Δ R/R max.: ±5% + 0.05 Ohm |
| Vibration | Frequency 10 to 500 Hz, displacement 1.5mm or acceleration 10g, three direction, total 6 hour (3x2 hour) | Δ R/R max.: ±5% + 0.05 Ohm |
| Endurance (at 70°C) | 1000 hour, loaded with Pn or Vmax 1.5 hours on and 0.5 hours off | Δ R/R max.: ±5% + 0.1 Ohm |
| Solderability | 8 hours steam or 16 hours 155°C, leads immersed 6mm for 2 sec ±0.5sec in a solder bath at 235±5°C | 95% coverage |
| Damp Heat Steady State | Duration: 56 days, 40°C, 90 to 95% RH | Δ R/R max.: ±3% + 0.1 Ohm |
| Resistance to Solvent | Solvent : Trichloroethylene for 3 min | Marking should be legible |

METAL GLAZE RESISTORS

Series: MGR

Dimensions:

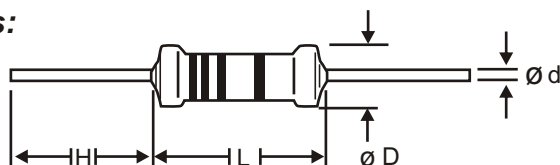

Derating Curve :

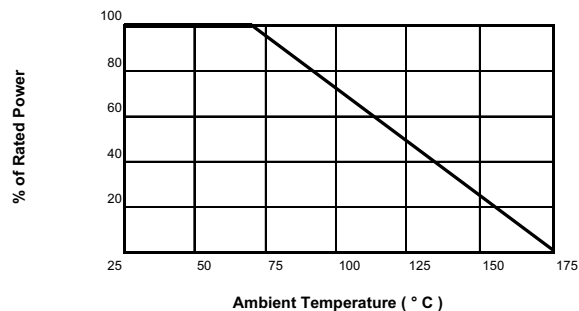

Physical Data :

| TYPE | RATED POWER | DIMENSION mm | | | | MAX. Working Voltage | Resistance Range |
|--------|-------------|--------------|-----------|------------|------------|----------------------|------------------|
| | | L | D | H (min) | d | | |
| MGR 25 | 0.25W | 6.3 ± 0.5 | 2.3 ± 0.5 | 28.1 ± 0.2 | 0.6 ± 0.03 | 1600 V DC | 100 K ~ 10 M |
| MGR 50 | 0.50W | 9.0 ± 0.5 | 3.5 ± 0.5 | 26.5 ± 0.2 | 0.6 ± 0.03 | 3500 V DC | 100 K ~ 10 M |

Performance Data :

| TEST | PROCEDURE | SPEC. |
|---------------------------------|--|---|
| Dielectric Withstanding Voltage | V-Block Method, 3X Rated Voltage Duration : 1 Min. | $\Delta R < \pm (0.5\% + 0.05 \text{ Ohm})$ No Breakdown |
| Insulation Resistance | V-Block Method, DC 500V Duration : 1 Min. | 10, 000 M Ohm |
| Temp. Cycling | 5 cycles of - 65°C, 25°C, +155°C, 25°C | $\Delta R < \pm (0.5\% + 0.05 \text{ Ohm})$ |
| Short Time Overload | 2.5X Rated Voltage Duration : 5 sec. | $\Delta R < \pm (1.5\% + 0.05 \text{ Ohm})$ |
| Damp Heat Steady State | 40°C/95% relative humidity, Duration : 56 Day. | $\Delta R < \pm (1.5\% + 0.05 \text{ Ohm})$ |
| Load Life | Rated Voltage at 70°C ambient Duration : 2000 Hrs. | $\Delta R < \pm (1.5\% + 0.05 \text{ Ohm})$ |
| Robustness of Terminations | Tensile: 10N Duration: 10 Sec. Bending : 180°, > 3 Bends Torsion : 3 Rotation of 360° Each | No Mechanical Damage |
| Resistance to Soldering Heat | Temp. 260°C ± 5°C Duration : 10 Sec. | $\Delta R < \pm (0.5\% + 0.05 \text{ Ohm})$ |
| Bump | 1500 Bump x 3 directions | $\Delta R < \pm (1.5\% + 0.05 \text{ Ohm})$ |
| Vibration (High Frequency) | 10 to 2000 Hz: m/S ² | $\Delta R < \pm (1.5\% + 0.05 \text{ Ohm})$ |
| Low Temp. Exposure | At - 65°C Duration : 2 Hrs. | $\Delta R < \pm (1.5\% + 0.05 \text{ Ohm})$ |
| High Temp. Exposure | At +155°C Duration : 16 Hrs. No Load Condition | $\Delta R < \pm (1.5\% + 0.05 \text{ Ohm})$ |
| Solderability | Dip Method, Solder Bath Temp. 230°C ± 5 °C. Duration 5 Sec. | 95% Coverage |
| Resistance to Solvent | Solvent : Trichloroethylene Duration : 3 Min. | Marking should be legible |

HIGH VOLTAGE METAL GLAZE RESISTORS

Series: MVR37

Features:

A metal glazed film is deposited on a high grade ceramic body. After a helical groove has been cut in the resistive layer, tinned electrolytic copper wires are welded to end caps. The resistors are coated with lacquer which provides electrical, mechanical and climatic protection.

Construction:

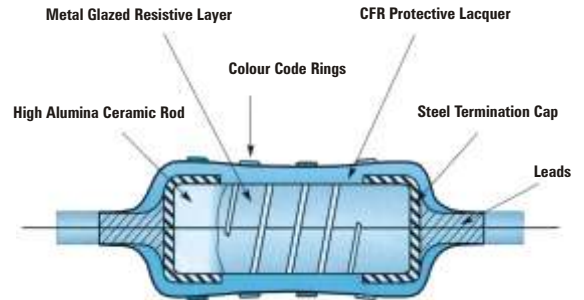

Technical Specifications :

| Description | Value |
|--|--|
| Resistance range | 100K Ohm to 33M Ohm |
| Resistance tolerance and series | ± 1% : E24/E96 Series ± 5% : E24 Series |
| Maximum dissipation at T _{amb} = 70°C | 0.5 W |
| Thermal Resistance (R _{th}) | 120 K / W |
| Temperature Co-efficient | ≤ ± 200 x 10 ⁻⁶ /K |
| Maximum Permissible Voltage | |
| DC | 3500 V |
| RMS | 2500 V |
| Dielectric withstanding voltage of the insulation for 1 minute | 700 V |
| Basic Specification | IEC 60115 - 1B |
| Climatic Category (IEC 60068) | 55/155/56 |
| Stability after : | |
| Load (1000 hours) | Δ R/R max.: ± (1.5% + 0.1 Ohm) |
| Accelerated damp heat test (6 days) | Δ R/R max.: ± (1.5% + 0.1 Ohm) |
| Long term damp heat test (56 days) | Δ R/R max.: ± (1.5% + 0.1 Ohm) |

Dimensions:

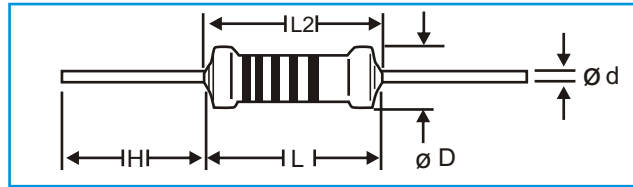

| TYPE | øD MAX (mm) | L MAX. (mm) | L2 MAX. (mm) | H MIN. (mm) | ød (mm) |
|-------|-------------|-------------|--------------|-------------|------------|
| MVR37 | 4.0 | 9.0 | 10.0 | 25 | 0.7 ± 0.03 |

Derating Curve :

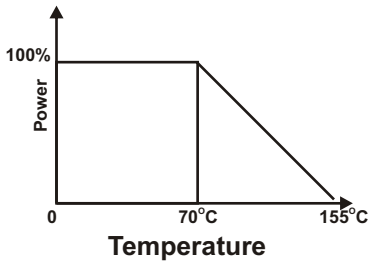

| LIMITING VALUES | | | |
|-----------------|----------------------|------|--------------------|
| TYPE | LIMITING VOLTAGE (V) | | LIMITING POWER (W) |
| | DC | AC | |
| MVR 37 | 3500 | 2500 | 0.5 |

Test Procedures and Requirement

| TYPE | REQUIREMENTS |
|--|--|
| Robustness of Termination Tensile 10N, 10 sec. Bending half number of samples Torsion other half of samples | Number of failures < 10 x 10 ⁻⁶ Number of failures < 10 x 10 ⁻⁶ No damage Δ R max.; ± (0.5% R + 0.05 Ohm) |
| Solderability | Good tinning; no damage |
| Resistance to soldering heat | Δ R max.; ± (0.5% R + 0.05 Ohm) |
| Rapid change of temperature | Δ R max.; ± (0.5% R + 0.05 Ohm) |
| Bump | No damage Δ R max.; ± (0.5% R + 0.05 Ohm) |
| Vibration | No damage Δ R max.; ± (0.5% R + 0.05 Ohm) |
| Climatic Sequence : Dry Heat Damp Heat (accelerated) 1st Cycle Cold Low Air Pressure Damp Heat (accelerated) remaining cycles | R _{ins} min.: 10 ³ M Ohm Δ R max.; ± (0.5% R + 0.1 Ohm) |
| Damp Heat (steady state) | Δ R max.; ± (1.5% R + 0.1 Ohm) |
| Endurance | Δ R max.; ± (1.5% R + 0.1 Ohm) |
| Temperature Coefficient | ≤ ± 200 ppm/°C |
| Voltage Proof on insulation | No Breakdown |
| Noise | Max. 2.5 μV/V |
| Insulation resistance | R _{ins} min.: 10 ⁴ M Ohm |
| Short time overload 2x limiting voltage Duration | Δ R max.; ± (2.0% R + 0.05 Ohm) 5 sec ON, 45 sec OFF - No of cycles 10 |

CARBON FILM RESISTORS

Series: CF / CFS

Construction:

Features:

- ▶ Economical as Produced on automated mass production.
- ▶ Superior quality raw materials to ensure stability & reliability.
- ▶ Available in T52 tape packing.

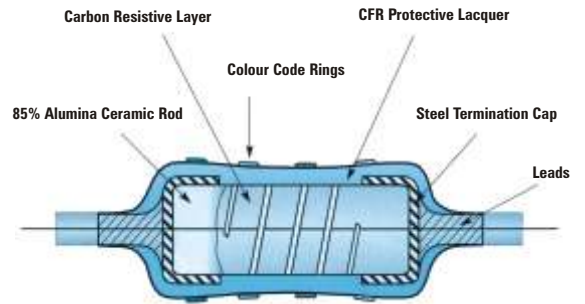

Dimensions:

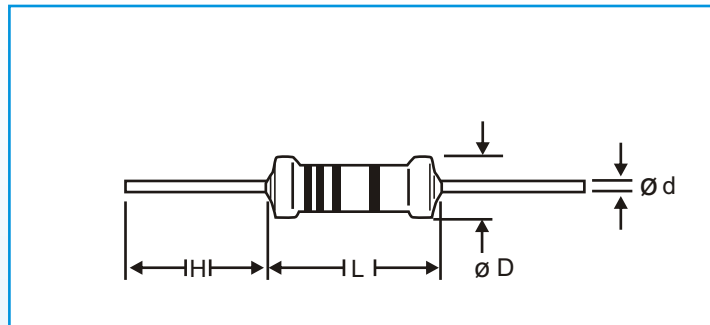

| TYPE | POWER RATING | TOL (±) | DIMENSION (mm) | | | | Max. Working Voltage | Max.Overload Voltage |
|---------|--------------|---------|----------------|-----------|---------|-------------|----------------------|----------------------|
| | | | L | D | H (min) | d | | |
| CF 25 | 0.25W | 5% | 6.5 ± 0.5 | 2.3 ± 0.2 | 28 | 0.60 ± 0.05 | 250V | 500V |
| CFS 50 | 0.5W | 5% | 6.5 ± 0.5 | 2.3 ± 0.2 | 28 | 0.60 ± 0.05 | 250V | 500V |
| CF 50 | 0.5W | 5% | 9.5 ± 1 | 3.5 ± 0.5 | 25 | 0.60 ± 0.05 | 350V | 700V |
| CFS 100 | 1W | 5% | 9.5 ± 1 | 3.5 ± 0.5 | 25 | 0.60 ± 0.05 | 350V | 700V |
| CF 100 | 1W | 5% | 12 ± 1 | 4.5 ± 0.5 | 25 | 0.80 ± 0.05 | 500V | 1000V |
| CFS 200 | 2W | 5% | 12 ± 1 | 4.5 ± 0.5 | 25 | 0.80 ± 0.05 | 500V | 1000V |
| CF 200 | 2W | 5% | 16 ± 1 | 5.5 ± 0.5 | 32 | 0.80 ± 0.05 | 500V | 1000V |
| CFS 300 | 3W | 5% | 16 ± 1 | 5.5 ± 0.5 | 32 | 0.80 ± 0.05 | 500V | 1000V |

Performance Data :

| TEST | PROCEDURE | SPEC. |
|---------------------------------|--|---|
| Dielectric Withstanding Voltage | V-Block Method, 3X Rated Voltage Duration : 1 Min. | $\Delta R < \pm (0.5\% + 0.05 \text{ Ohm})$ |
| Insulation Resistance | V-Block Method, DC 500V Duration : 1 Min. | $> 10,000 \text{ M Ohm}$ |
| Temp. Cycling | 5 cycles of - 65°C, 25°C, +155°C, 25°C | $\Delta R = (1\% + 0.05 \text{ Ohm})$ |
| Short Time Overload | 2.5X Rated Voltage Duration : 5 sec. | $\Delta R = (1\% + 0.05 \text{ Ohm})$ |
| Damp Heat Steady State | 40°C95% relative humidity, Duration : 56 Day. | $\Delta R = (5\% + 0.05 \text{ Ohm})$ |
| Load Life | Rated Voltage at 70°C ambient Duration : 2000 Hrs. | $\Delta R = (5\% + 0.05 \text{ Ohm})$ |
| Robustness of Terminations | Tensile: 10N Duration: 10 Sec. Bending : 180°, > 3 Bends Torsion : 3 Rotation of 360° Each | $\Delta R = (0.5\% + 0.05 \text{ Ohm})$ |
| Resistance to Soldering Heat | Temp. 260°C \pm 5°C Duration : 10 Sec. | $\Delta R = (1\% + 0.05 \text{ Ohm})$ |
| Shock (Medium Impact) | 1 Km/S ² | $\Delta R = (1\% + 0.05 \text{ Ohm})$ |
| Vibration (High Frequency) | 10 to 2000 Hz: m/S ² | $\Delta R = (1\% + 0.05 \text{ Ohm})$ |
| Low Temp. Exposure | At - 65°C Duration : 2 Hrs. | $\Delta R = (1\% + 0.05 \text{ Ohm})$ |
| High Temp. Exposure | At +155°C Duration : 16 Hrs. No Load Condition | $\Delta R = (5\% + 0.05 \text{ Ohm})$ |
| Solderability | Dip Method, Solder Bath Temp. 230°C \pm 5 °C. Duration 5 Sec. | 95% Coverage |
| Resistance to Solvent | Solvent : Trichloroethylene Duration : 3 Min. | Marking should be legible |

DERATING CURVE

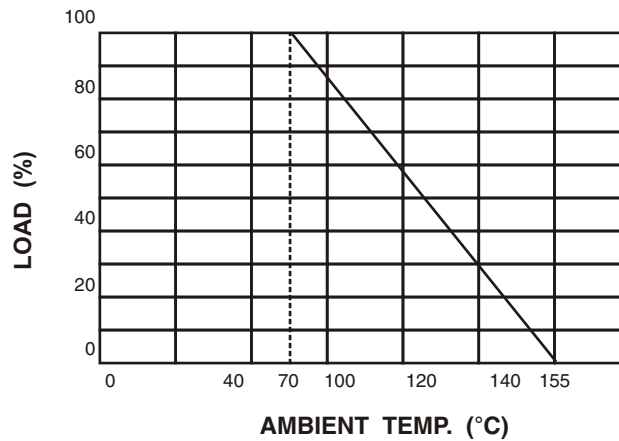

SURFACE TEMP. RISE

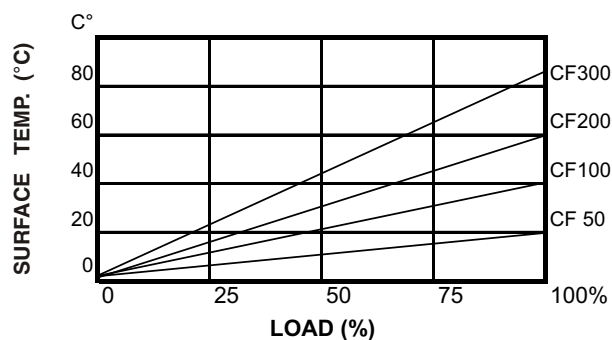

CERAMIC ENCASED (WIRE WOUND RESISTORS)

Series: MCA / MCR

Construction:

Features:

- ▶ Fully welded construction.
- ▶ Flameproof inorganic construction.
- ▶ Enhanced heat dissipation.
- ▶ Operating temperature -55°C to +275°C.
- ▶ MO film element utilized for higher resistance values.
- ▶ Any special design on request.

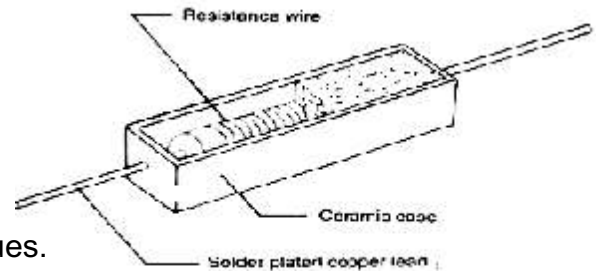

Ceramic Encased Boat Type (MCA)

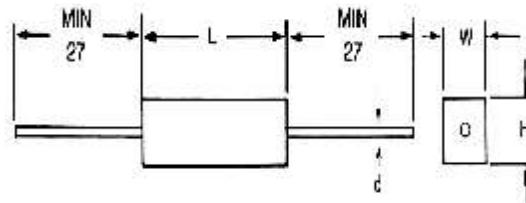

| MCA | DIMENSION (mm) | | | | RESISTANCE RANGE (Ω) | | MAX WORKING VOLTAGE |
|-----|----------------|-------------|-------------|--------------|-------------------------------|-----------------------------|---------------------|
| | L \pm 1.5 | W \pm 1.0 | H \pm 1.0 | d \pm 0.05 | WIRE WOUND | MO | |
| 2W | 18.0 | 7.0 | 7.0 | 0.65 | 0.1 Ω ~ 50 Ω | 51 Ω ~ 20K Ω | 150V |
| 3W | 22.0 | 8.0 | 8.0 | 0.75 | 0.1 Ω ~ 50 Ω | 51 Ω ~ 33K Ω | 350V |
| 5W | 22.0 | 9.5 | 9.0 | 0.75 | 0.1 Ω ~ 100 Ω | 101 Ω ~ 50K Ω | 350V |
| 7W | 35.0 | 9.5 | 9.0 | 0.75 | 0.1 Ω ~ 500 Ω | 501 Ω ~ 50K Ω | 500V |
| 10W | 48.0 | 9.5 | 9.0 | 0.75 | 0.1 Ω ~ 500 Ω | 501 Ω ~ 50K Ω | 750V |
| 15W | 48.0 | 12.5 | 12.0 | 0.75 | 0.5 Ω ~ 1K | 1K Ω ~ 150K Ω | 1000V |
| 20W | 60.0 | 14.0 | 13.5 | 0.75 | 0.5 Ω ~ 1K | 1K Ω ~ 150K Ω | 1000V |

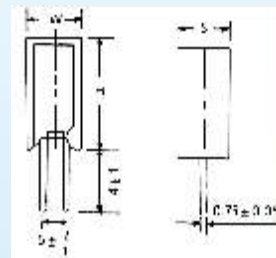

Ceramic Encased Vertical Boat Type (MCR)

| MCR | DIMENSION(mm) | | | RESISTANCE RANGE (Ω) | |
|------|---------------|-----------|-----------|-------------------------------|-----------------------------|
| | H \pm 1.5 | W \pm 1 | S \pm 1 | WIREWOUND | MO |
| 2W | 20 | 11 | 7.5 | 0.1 Ω ~ 50 Ω | 51 Ω ~ 20K Ω |
| 3W | 25 | 12 | 9 | 0.1 Ω ~ 50 Ω | 51 Ω ~ 33K Ω |
| 5W | 25 | 13 | 9 | 0.1 Ω ~ 100 Ω | 101 Ω ~ 50K Ω |
| 7W | 39 | 13 | 9 | 0.1 Ω ~ 500 Ω | 501 Ω ~ 50K Ω |
| 10W | 51 | 13 | 9 | 0.1 Ω ~ 500 Ω | 501 Ω ~ 50K Ω |
| 10WS | 35 | 16 | 12 | 0.5 Ω ~ 1K | 1K Ω ~ 150K Ω |

CERAMIC ENCASED (TUBE TYPE) MCAT

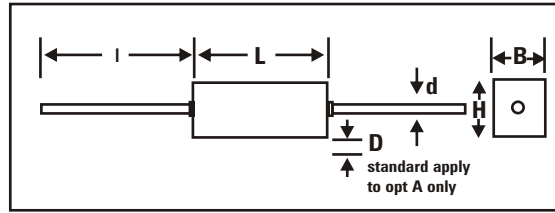

| Wattage | MCA T Series | Resistance Ranges | | Physical Dimension in mm | | | | |
|---------|--------------|-------------------|-----|--------------------------|---------|---------|---------|--------|
| | | Min | Max | B ± 1.0 | H ± 1.0 | L ± 1.5 | d ± 0.1 | l(min) |
| 1W | MCA T1 | 0R01 | 1K5 | 6.0 | 6.0 | 15.0 | 0.8 | 28.0 |
| 2W | MCA T2 | 0R01 | 2K | 6.5 | 6.5 | 15.0 | 0.8 | 28.0 |
| 3W | MCA T3 | 0R01 | | 7.0 | 7.0 | 15.0 | 0.8 | 28.0 |
| 4W | MCA T4 | 0R01 | 4K7 | 6.5 | 6.5 | 20.0 | 0.8 | 28.0 |
| 5W | MCA T5 | 0R01 | 6K8 | 6.5 | 6.5 | 25.0 | 0.8 | 28.0 |
| 6W | MCA T5 A | 0R01 | | 9.0 | 9.0 | 20.0 | 0.8 | 28.0 |
| | MCA T6 | 0R01 | | 8K2 | 9.0 | 9.0 | 25.0 | 0.8 |

Performance:

| Test Items | Condition | Spec. |
|-------------------------|-------------------------------------|--------------|
| Resistance Temp. Coeff. | - 55° ~ +155°C | ± 300 ppm/°C |
| Short Time Overload | 5 times rated wattage for 5 sec | Δ R < ± 2% |
| Rated Load | Rated voltage 30 min | Δ R < ± 1% |
| Insulation Resistance | 500v megger | 500MΩ |
| Temp. Cycle | - 30°C ~ + 85°C for 5 cycles | Δ R < ± 1% |
| Load Life | 70°C On-Off cycle 1000 hrs | Δ R < ± 5% |
| Damp Heat | 40°C 95%RH On-Off cycle 1000 hrs | Δ R < ± 3% |

DERATING CURVE

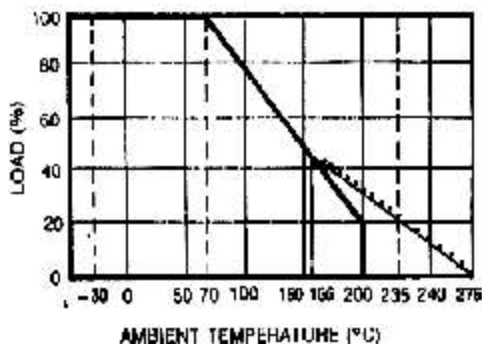

TEMPERATURE RISE AT 25°C

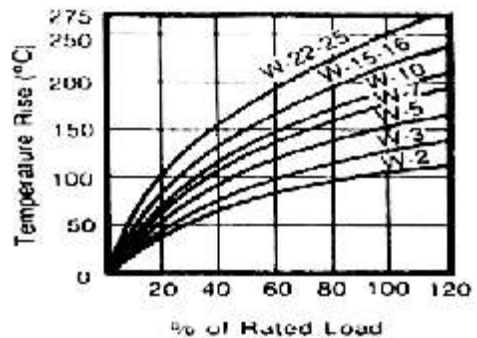

SILICON COATED AXIAL WIREWOUND RESISTORS

Series: MSA

Dimensions:

Features:

- ▶ Flameproof Coating Compatible with UL standards
- ▶ 0.5W to 12 Watts rating available
- ▶ Tolerances up to $\pm 3\%$ available
- ▶ Low TCR on request can be provided
- ▶ Industrial & Professional Application

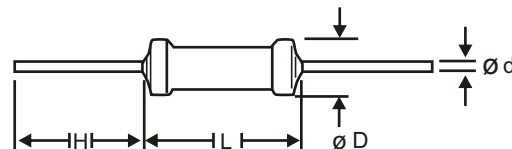

Physical Data :

| TYPE | WATTS | DIMENSIONS (mm) | | | | RESISTANCE |
|---------|-------|-----------------|-------------|--------------|---------|--------------|
| | | L ± 1.5 | D ± 1.5 | d ± 0.05 | H (MIN) | RANGE |
| MSA 0.5 | 0.5W | 9.5 | 3.5 | 0.6 | 27 | 0.1E to 47E |
| MSA 1 | 1 W | 12 | 4.0 | 0.8 | 27 | 0.1E to 150E |
| MSA 2 | 2 W | 16 | 5.5 | 0.8 | 27 | 0.1E to 200E |
| MSA 3 | 3 W | 18 | 5.5 | 0.8 | 27 | 0.1E to 400E |
| MSA 5 | 5 W | 22 | 6.5 | 0.8 | 27 | 0.1E to 1K |
| MSA 7 | 7 W | 25 | 8.0 | 0.8 | 27 | 0.1E to 1K |
| MSA 8 | 8 W | 43 | 8.0 | 0.8 | 27 | 0.1 E to 2K |
| MSA 10 | 10 W | 53 | 8.0 | 0.8 | 27 | 0.1 E to 10K |

Note : Higher values & Non Inductive type available on request.

Performance Data :

| TEST | REQUIREMENT |
|---------------------------------|---|
| Dielectric withstanding voltage | No Breakdown / Flashover |
| Insulation Resistance | $> 10^3$ M Ohms |
| Short Time Overload | $\Delta R < \pm 2\% + 0.05$ Ohms |
| Robustness of Termination | No Mechanical Damage |
| Solderability | $> 95\%$ coverage of solder |
| Temperature Cycling | $\Delta R < \pm 2\% + 0.05$ Ohms |
| Life Electrical | $\Delta R < \pm 5\% + 0.05$ Ohms |
| Climatic & Damp Heat | $\Delta R < \pm 5\%$ & No Mechanical Damage |
| Flammability | Within Specific Limits |
| TCR | 100 or 200ppm/°C |

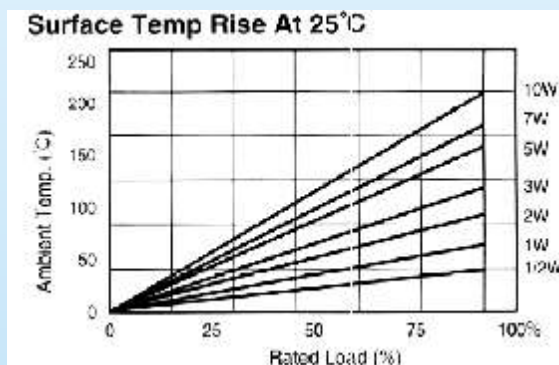
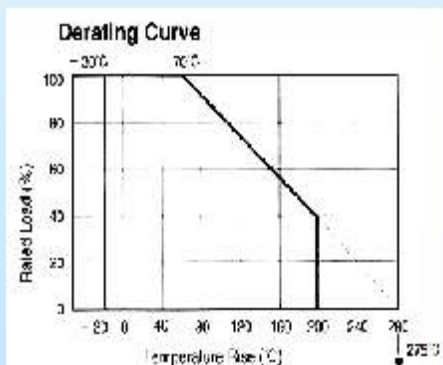

POWER RADIAL TYPE WIREWOUND RESISTORS

Series: MSR

Dimension:

Features:

- ▶ Widest range in the industry.
- ▶ High performance for low cost.
- ▶ High-temperature flame proof silicon coating.
- ▶ Tolerance to ± 5 , $\pm 10\%$.
- ▶ Better tolerance available on request.
- ▶ Custom sizes and terminations available.

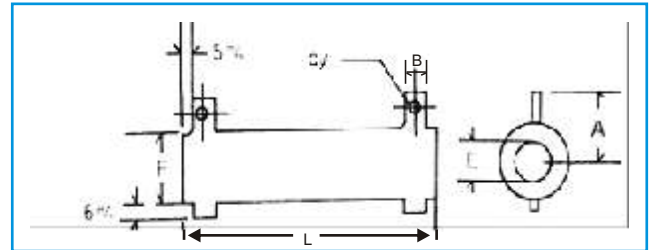

Physical Data:

| RATED WATTS | D TYPE DIMENSIONS (m/m) | | | | |
|-------------|-------------------------|----|----|----|----|
| | L | F | E | A | B |
| 10W | 45 | 12 | 6 | 15 | 4 |
| 20W | 60 | 17 | 8 | 20 | 5 |
| 30W | 80 | 17 | 8 | 20 | 5 |
| 40W | 110 | 17 | 8 | 20 | 5 |
| 50W | 110 | 25 | 16 | 30 | 8 |
| 60W | 90 | 28 | 18 | 32 | 8 |
| 80W | 110 | 28 | 18 | 32 | 8 |
| 100W | 140 | 28 | 18 | 32 | 8 |
| 120W | 160 | 28 | 18 | 32 | 8 |
| 150W | 195 | 28 | 18 | 32 | 8 |
| 160W | 185 | 35 | 24 | 38 | 8 |
| 200W | 210 | 35 | 24 | 38 | 8 |
| 260W | 210 | 40 | 25 | 38 | 10 |
| 300W | 260 | 40 | 25 | 38 | 10 |
| 400W | 330 | 40 | 25 | 38 | 10 |
| 500W | 330 | 50 | 35 | 50 | 15 |
| 600W | 400 | 50 | 35 | 50 | 15 |
| 800W | 460 | 60 | 40 | 60 | 15 |
| 1000W | 540 | 60 | 40 | 60 | 15 |
| 1200W | 650 | 65 | 42 | 62 | 15 |

Technical Data:

| | |
|--------------------------------|---|
| Tolerance | $\pm 1\%$, $\pm 2\%$, $\pm 5\%$ & $\pm 10\%$ |
| Temperature coefficient | ± 200 ppm/ $^{\circ}$ C |
| Power dissipation | Rated at 70 $^{\circ}$ C Ambient derated linearly to Zero power at 350 $^{\circ}$ C |
| Load life stability | $\Delta R < \pm 5\%$ full load dissipation for 1000 hrs |
| Maximum Voltage | \sqrt{PR} Where P = Power in Watt, R = Resistance in ohms |
| Overload | 10x rated power for 5 sec., $\Delta R = \pm 2\%$ |
| Temperature Rise | 250 - 325 $^{\circ}$ C |
| Operating Temp. | -55 $^{\circ}$ C to +350 $^{\circ}$ C |
| Dielectric Strength | 1000 VAC |

Temp. Characteristics :

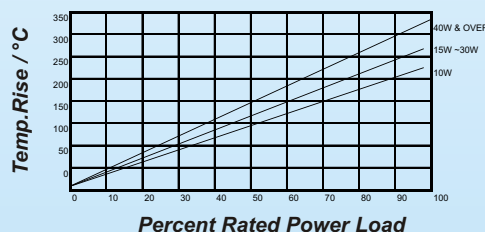

FLAMEPROOF FUSIBLE RESISTORS

Series: MFF / MFFS

Features:

- ▶ Suitable to apply in transistor protection circuit.
- ▶ Small in sizes with low cost.
- ▶ Non combustible insulating coat, solvent proof and excellent application in high temperature.
- ▶ Good TCR ± 200 PPM/ $^{\circ}$ C
- ▶ Uniform in fusing time.
- ▶ Film & wirewound elements available as per requirement.

Dimensions :

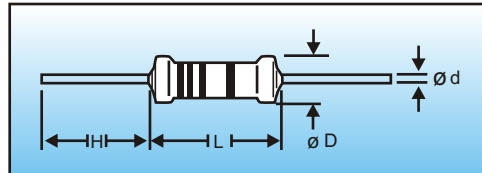

General Specification :

| Style | | Dimensions | | | | Resistance | Max Working Voltage | Dielectric Withstanding Voltage |
|-------|------|---------------|---------------|----------------|--------|---------------------------|---------------------|---------------------------------|
| MFF | MFFS | L | D | d | H(MIN) | Range | | |
| 1/4 W | 1/2W | 6.3 ± 0.5 | 2.3 ± 0.2 | 0.6 ± 0.02 | 27 | $1 \Omega \sim 10K\Omega$ | 250V | 500V |
| 1/2 W | 1W | 9.5 ± 1 | 3.5 ± 0.5 | 0.6 ± 0.02 | 27 | $1 \Omega \sim 10K\Omega$ | 250V | 500V |
| 1W | 2W | 12 ± 1 | 4.5 ± 0.5 | 0.8 ± 0.02 | 27 | $1 \Omega \sim 10K\Omega$ | 250V | 500V |
| 2W | 3W | 16 ± 1 | 5.5 ± 0.5 | 0.8 ± 0.02 | 27 | $1 \Omega \sim 10K\Omega$ | 250V | 500V |

Derating Curve :

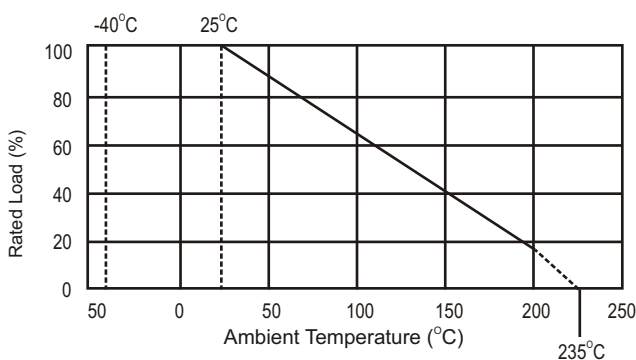

Fusing Characteristics :

| Resistance Range | Fusing Power | |
|-----------------------------|------------------|------------------|
| | MFF | MFFS |
| $0.22 \Omega \sim 1 \Omega$ | 32 x Rated Power | 16 x Rated Power |
| $1.1 \Omega \sim 2 \Omega$ | 25 x Rated Power | 16 x Rated Power |
| $2.1 \Omega \sim 1 \Omega$ | 16 x Rated Power | 16 x Rated Power |
| $12 \Omega \sim 10K \Omega$ | 16 x Rated Power | 16 x Rated Power |
| Fusing Time : within 60 sec | | |

Note: 1. Same fusing chart for MFF & MFFS series.
 2. Special fusing time according to customers, spec is also available.

Characteristic :

| Characteristics | Condition | Spec. |
|--------------------------|--|-----------------------------|
| Resistance Temp. Coeff. | - 30 $^{\circ}$ C ~ 150 $^{\circ}$ C | ± 200 ppm/ $^{\circ}$ C |
| Short Time Over Load | 2 times of rated voltage for 5 sec. | $\pm 2\%$ |
| Insulation Resistance | 500 v megger | 1.000M Ω |
| Temp. Cycle | - 30 $^{\circ}$ C ~ 85 $^{\circ}$ C for 5 cycles | $\pm 1\%$ |
| Load Life | 70 $^{\circ}$ C on-off cycle 1,000 hrs. | $\pm 5\%$ |
| Moisture Proof Load Life | 40 $^{\circ}$ C 95% RH on-off cycle 1000 hrs | $\pm 1\%$ |
| Solderability | 270 $^{\circ}$ C for 3 sec. | smooth & shiny appearance |
| Incombustibility | 16 times of rated wattage for 5 min. | not flamed |
| Operating Temp. | -40 $^{\circ}$ C ~ 240 $^{\circ}$ C | |

* Total resistance change: ($\Delta R\% + 0.05 \Omega$)

Zero - Ohms Resistors

Series: ZOR

Features:

- ▶ Insulated body allows to be passed over tracks without short circuiting.
- ▶ Can be tape mounted for auto insertion machines.
- ▶ Remove the need of double sided PCB boards in some cases.

Dimension (mm) :

| WATT | L | D | H | d |
|-------|-----------|-----------|--------|-------------|
| 1/4 W | 6.3 ± 0.2 | 2.3 ± 0.2 | 25 MIN | 0.60 ± 0.05 |

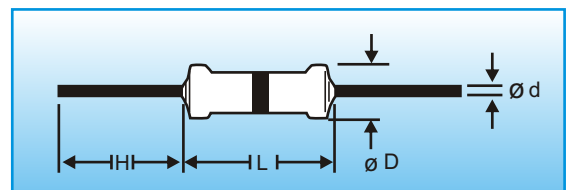

Performance Data :

| Description | | Specification |
|---------------------------|-------|-------------------|
| Current carrying capacity | amps | 5 max |
| Isolation voltage | volts | 500 dc or ac peak |
| Insulation resistance | ohms | > 1 G |
| Voltage proof | volts | 350 dc or ac peak |

Tape Jumper

| Description | Dimension (mm) | | |
|------------------------------|----------------|--------|--------|
| | T26 | T42 | T52 |
| Inner tape width A | 26 ± 1 | 42 ± 1 | 52 ± 1 |
| Pitch P | 5 ± 0.2 | | |
| Tape mismatch L ₃ | 0.5 max | | |
| Lead bending Z | 1 max | | |
| Tape width T | 6.0 ± 1.0 | | |
| Lead adhesion length t | 3.2 min | | |
| Lead projection R | 0 | | |

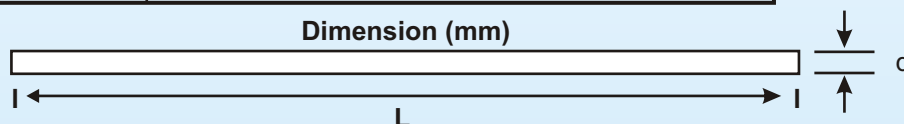
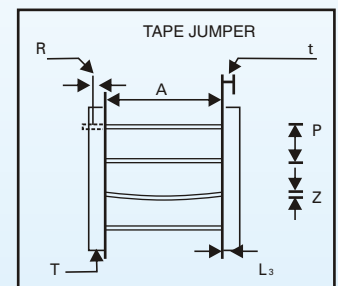

| STYLE | L ± 1 | d | TOI | Current max |
|----------|-------|------|--------|-------------|
| MFJ 0.45 | | | | |
| T26 | 34 | 0.45 | ± 0.05 | 3.5 Amp |
| T42 | 50 | | | |
| T52 | 60 | | | |
| MFJ 0.60 | | | 0 | |
| T26 | 34 | | | 3.5 Amp |
| T42 | 50 | 0.60 | -0.05 | |
| T52 | 60 | | | |

PACKING INFORMATIONS

TAPING DETAILS :

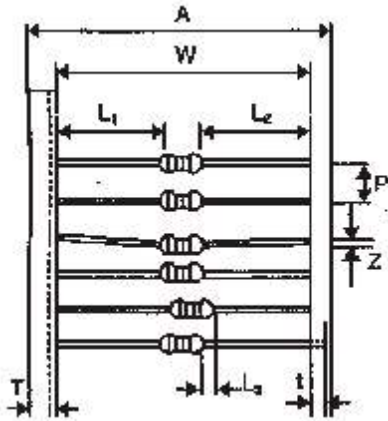

| Dimension (mm) | Nominal Taping Width | |
|------------------------|----------------------|-------------------|
| | 52 mm for universal | 26mm for PANASERT |
| Inner tape width W | 52 ± 1 | 26.5 ± 1 |
| Outer tape width A | 64 ± 1 | 38 ± 1 |
| Pitch P | 5 ± 0.4 | 5 ± 0.4 |
| Center deviation L1-L2 | 1.0 (max) | 1.0 (max) |
| Body Deviation L3 | 0.5 (max) | 0.5 (max) |
| Lead bending Z | 1.0 (max) | 1.0 (max) |
| Tape width T | 6.0 ± 1.0 | 6.0 ± 1.0 |
| Lead adhesion length t | 4.0 (min) | 4.0 (min) |
| Lead Projector R | 0 | 0 |

BULK PACKING:



| TYPE | PCS Per Poly Bag | PCS |
|------|------------------|-------|
| 1/8W | 500 | 1,000 |
| 1/4W | 500 | 1,000 |
| 1/2W | 200 | 1,000 |
| 1W | 100 | 500 |

* Inner Package
(Polyethylene Bag)

* Outer Package
(Carton Box)

TAPE IN BOX:

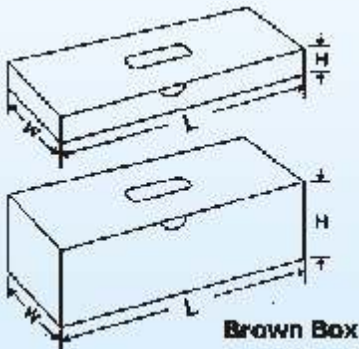

| TYPE | PCS PER Poly Bag | PCS Per Box | |
|------|------------------|-------------|-----------|
| | | Blue Box | Brown Box |
| 1/8W | 1,000 | 1,000 | 5,000 |
| 1/4W | 1,000 | 1,000 | 5,000 |
| 1/2W | 500 | 500 | 2,500 |
| 1W | 250 | 250 | 1,250 |

| TYPE | Dimension (mm) | | |
|------|----------------|-------|------|
| | L | W | H |
| 1/8W | 260±5 | 80±2 | 25±2 |
| 1/4W | 260±5 | 77±2 | 20±1 |
| 1/2W | 270±5 | 75±2 | 48±2 |
| 1W | 277±5 | 104±2 | 83±2 |
| 2W | 265±5 | 110±2 | 85±2 |

TAPE IN REEL:

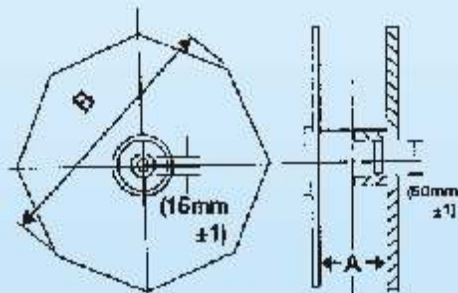

| REEL DIMENSION (mm) | | | |
|---------------------|---------------------|--------------------|----------|
| TYPE | Across Flanges A | Across Points B | Quantity |
| | | | Per Reel |
| 1/8W | 72 Max | 310 Max | 5,000 |
| 1/4W | 72 Max | 310 Max | 5,000 |
| 1/2W | 72 Max | 310 Max | 2,500 |
| 1W | 72 Max | 310 Max | 1,000 |

Standard Resistor Value

| E-5 ($\pm 20\%$) | | | | | | | | | | | |
|--------------------|----|----|----|----|----|--|--|--|--|--|--|
| 10 | 15 | 22 | 33 | 47 | 68 | | | | | | |

| E-12 ($\pm 10\%$) | | | | | | | | | | | |
|---------------------|----|----|----|----|----|----|----|----|----|----|----|
| 10 | 12 | 15 | 18 | 22 | 27 | 33 | 39 | 47 | 56 | 68 | 82 |

| E-24 ($\pm 2\%$, $\pm 5\%$) | | | | | | | | | | | |
|--------------------------------|----|----|----|----|----|----|----|----|----|----|----|
| 10 | 11 | 12 | 13 | 15 | 16 | 18 | 20 | 22 | 24 | 27 | 30 |
| 33 | 36 | 39 | 43 | 47 | 51 | 56 | 62 | 68 | 75 | 82 | 91 |

| E-96 ($\pm 1\%$) | | | | | | | | | | | |
|--------------------|------|------|------|------|------|------|------|------|------|------|------|
| 10.0 | 10.2 | 10.5 | 10.7 | 11.0 | 11.3 | 11.5 | 11.8 | 12.1 | 12.4 | 12.7 | 13.0 |
| 13.3 | 13.7 | 14.0 | 14.3 | 14.7 | 15.0 | 15.4 | 15.8 | 16.2 | 16.5 | 16.9 | 17.4 |
| 17.8 | 18.2 | 18.7 | 19.1 | 19.6 | 20.0 | 20.5 | 21.0 | 21.5 | 22.1 | 22.6 | 23.2 |
| 23.7 | 24.3 | 24.9 | 25.5 | 26.1 | 26.7 | 27.4 | 28.2 | 28.7 | 29.4 | 30.1 | 30.9 |
| 31.6 | 32.4 | 33.2 | 34.0 | 34.8 | 35.7 | 36.5 | 37.4 | 38.3 | 39.2 | 40.2 | 41.2 |
| 42.2 | 43.2 | 44.2 | 45.3 | 46.4 | 47.5 | 48.7 | 49.9 | 51.1 | 52.3 | 53.6 | 54.9 |
| 55.5 | 57.6 | 59.0 | 60.4 | 61.9 | 63.4 | 64.9 | 66.5 | 68.1 | 69.8 | 71.5 | 73.2 |
| 75.0 | 76.8 | 78.7 | 80.6 | 82.5 | 84.5 | 86.6 | 88.7 | 90.9 | 93.1 | 95.3 | 97.6 |

| E-192 ($\pm 1\%$) | | | | | | | | | | | |
|---------------------|------|------|------|------|------|------|------|------|-------|------|------|
| 10.0 | 10.1 | 10.2 | 10.4 | 10.5 | 10.6 | 10.7 | 10.9 | 11.0 | 11.1 | 11.3 | 11.4 |
| 11.5 | 11.7 | 11.8 | 12.0 | 12.1 | 12.9 | 12.4 | 12.6 | 12.7 | 12.9 | 13.0 | 13.2 |
| 13.3 | 13.5 | 13.7 | 13.8 | 14.0 | 14.2 | 14.3 | 14.5 | 14.7 | 14.9 | 15.0 | 15.2 |
| 15.4 | 15.6 | 15.8 | 16.0 | 16.2 | 16.4 | 16.5 | 16.7 | 16.9 | 17.2 | 17.4 | 17.6 |
| 20.5 | 20.8 | 21.0 | 21.3 | 21.5 | 21.8 | 22.1 | 22.9 | 22.6 | 22.9 | 23.2 | 23.4 |
| 23.7 | 24.0 | 24.3 | 24.6 | 24.9 | 25.2 | 25.5 | 25.8 | 26.1 | 264.0 | 26.7 | 27.1 |
| 27.4 | 27.7 | 28.0 | 28.4 | 28.7 | 29.1 | 29.4 | 29.8 | 30.1 | 30.5 | 30.9 | 31.2 |
| 31.6 | 32.0 | 32.4 | 32.8 | 33.2 | 33.6 | 34.0 | 34.4 | 34.8 | 35.2 | 35.7 | 36.1 |
| 36.5 | 37.0 | 37.4 | 37.9 | 38.3 | 38.8 | 39.2 | 39.7 | 40.2 | 40.7 | 41.2 | 41.7 |
| 42.2 | 42.7 | 43.2 | 43.7 | 44.2 | 44.8 | 45.3 | 45.9 | 46.4 | 47.0 | 47.5 | 48.1 |
| 46.7 | 49.3 | 49.9 | 50.5 | 51.1 | 51.7 | 52.3 | 53.0 | 53.6 | 54.2 | 54.9 | 55.6 |
| 56.2 | 56.9 | 57.6 | 58.3 | 59.0 | 59.7 | 60.4 | 61.2 | 61.9 | 62.6 | 63.4 | 64.2 |
| 64.9 | 65.7 | 66.5 | 67.3 | 68.1 | 69.0 | 69.8 | 70.6 | 71.5 | 72.3 | 73.2 | 74.1 |
| 75.0 | 75.9 | 76.8 | 77.7 | 78.7 | 79.6 | 80.6 | 81.6 | 82.5 | 83.5 | 84.5 | 85.6 |
| 86.6 | 87.6 | 88.7 | 89.8 | 90.9 | 92.0 | 93.1 | 94.2 | 95.3 | 96.5 | 97.6 | 98.8 |

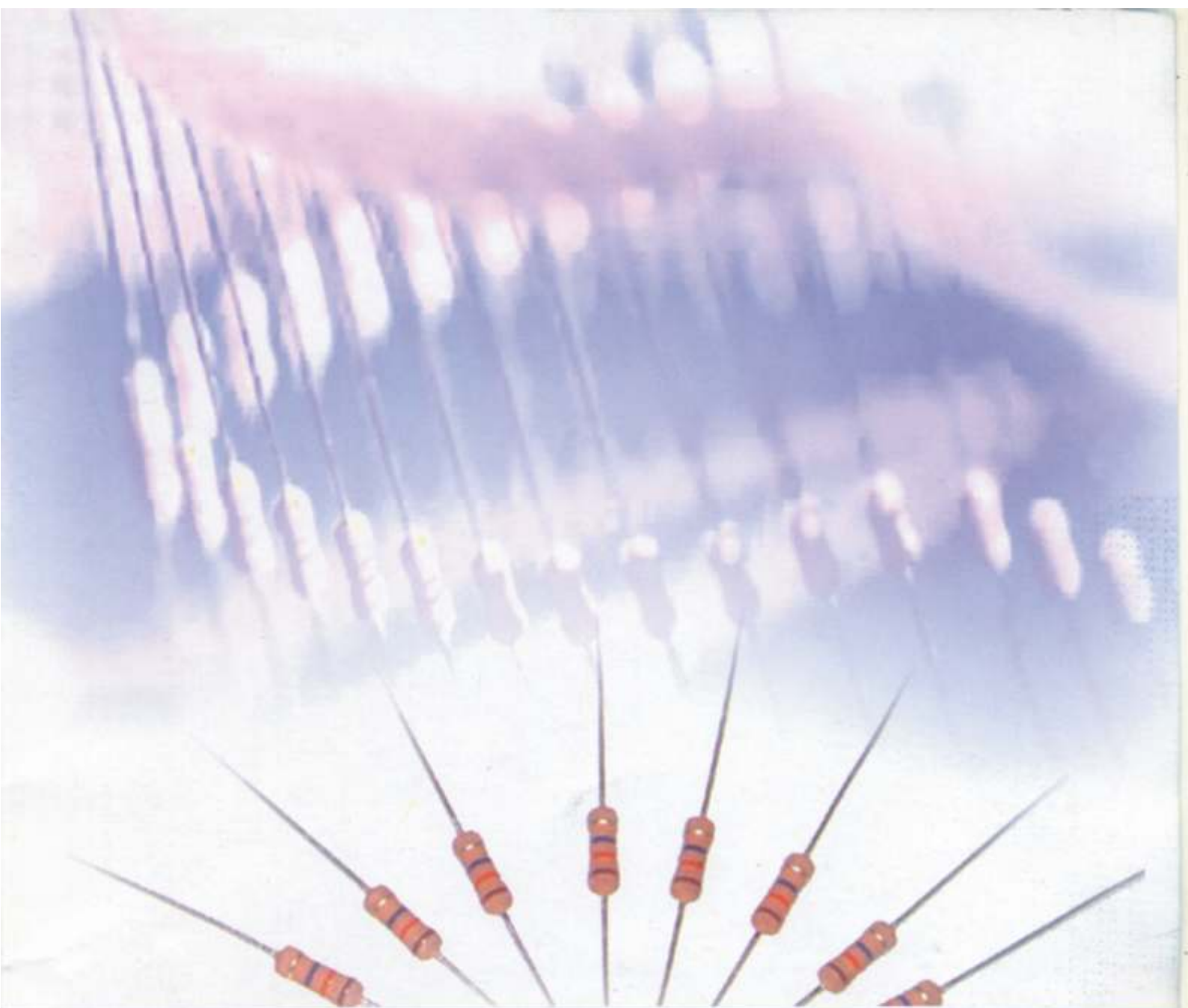

| Type | Rated Power | Tolerance | TCR |
|---|--|--|--|
| MFR MFR P MFS MFS P | 0.125W, 0.25W, 0.5W, 1W, 2W | ± 0.01% to ± 1% ± 0.02% to ± 0.1% ± 1% to ± 5% | ± 25, ± 50, ± 100 ppm/°C ± 5, ± 10, ± 15, ± 25 ppm/°C ± 25, ± 50, ± 100 ppm/°C ± 5, ± 10, ± 15, ± 25 ppm/°C |
| CFR | 0.25W, 0.5W, 1W, 2W | ± 5% | ± 200 ppm/OC |
| MOR MPR01, MPR02, MPR 03 Flameproof Fusible Resistors MGR MVR37 | 0.5W, 1W, 2W 0.25W, 0.5W, 1W, 2W, 3W 0.25W, 0.5W 2W | ± 1% TO ± 5% ± 1% TO ± 5% ± 1% TO ± 5% ± 1% TO ± 5% | ± 200 ppm/OC ± 25ppm/°C to 100ppm/°C ± 200ppm/°C ± 200ppm/°C ± 200ppm/°C |
| RNC AXIAL RADIAL | RNC 55 - 0.125 RNC 60 - 0.25 0.5W 1W | ± 0.02% TO ± 1% ± 0.02% TO ± 1% ± 0.01% TO ± 1% ± 0.01% TO ± 1% | ± 5, ± 10, ± 15, ± 25 ppm/°C ± 5, ± 10, ± 15, ± 25 ppm/°C ± 5, ± 10, ± 15, ± 25 ppm/°C ± 5, ± 10, ± 15, ± 25 ppm/°C |
| WIRE WOUND | | | |
| MSR MCA/MCR MSA | 10W TO 1200W 2W TO 20W 0.5W TO 10W | ± 5% TO ± 10% ± 5% TO ± 10% upto ± 3% | ± 200 ppm/°C ± 200 ppm/°C ± 200 ppm/°C |

METAL FILM RESISTORS

560 KΩ ± 1% 50 PPM

6-BAND-CODE



METAL FILM RESISTORS

270Ω ± 5%

5-BAND-CODE



| COLOUR | 1ST BAND | 2ND BAND | 3RD BAND | MULTIPLIER | TOLERANCE | TCR |
|--------|----------|----------|----------|------------|------------|--------|
| BLACK | 0 | 0 | 0 | 1Ω | ±0.01% | 200PPM |
| BROWN | 1 | 1 | 1 | 10Ω | ±1% [F] | 100PPM |
| RED | 2 | 2 | 2 | 100Ω | ±2% [G] | 50PPM |
| ORANGE | 3 | 3 | 3 | 1KΩ | | 15PPM |
| YELLOW | 4 | 4 | 4 | 10KΩ | | 25PPM |
| GREEN | 5 | 5 | 5 | 100KΩ | ±0.5% [D] | |
| BLUE | 6 | 6 | 6 | 1MΩ | ±0.25% [V] | |
| VIOLET | 7 | 7 | 7 | 10MΩ | ±0.10% [B] | |
| GREY | 8 | 8 | 8 | | ±0.05% [A] | |
| WHITE | 9 | 9 | 9 | | | |
| GOLD | | | | 0.1Ω | ±5% [J] | |
| SILVER | | | | 0.01Ω | ±10% [K] | |

